



# 75 GPM SAND FILTER SYSTEM

## Product Specification Sheet

### DESCRIPTION

- Skid mounted sand media filter pods with automatic backwashing.
- Designed for general-purpose water filtration of organic and inorganic solids.

### FEATURES

- Dual 18" sand filter pods
- Pods are constructed of stainless steel
- AC powered automatic filter backwash system with timer controller
- Skid mounted, constructed of carbon steel with forklift slots and eye hooks

### TECHNICAL

- Max operating pressure: 100 psi
- Flow range: 60-90 gpm
- Overall dimensions: 57" x 40" x 64"
- Inlet and outlet size: 3" (inlet) and 2" (outlet) camlocks quick-disconnect
- Media sand requirement: 500 lbs.
- Dry weight: 575 lbs.
- Shipping weight with sand fill: 1,075 lbs.
- Filtration area: 3.6 ft.<sup>2</sup>
- Backwash line size: 3"
- Electrical: 120/240 volts, single phase

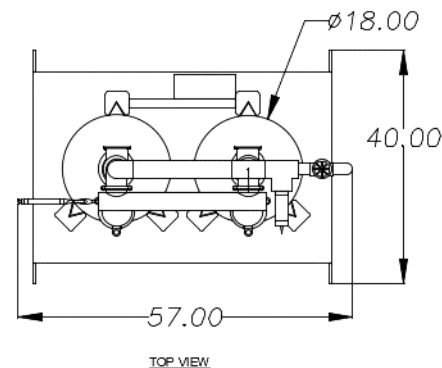

TOP VIEW

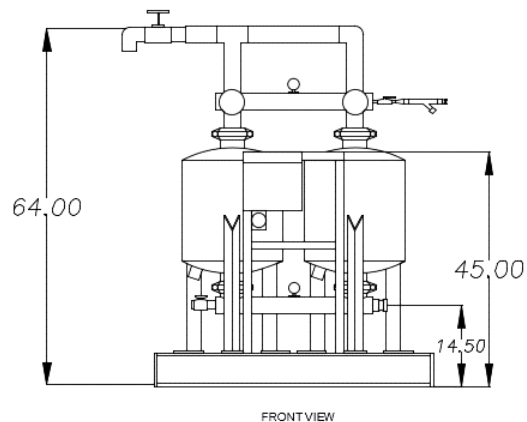

FRONT VIEW