



# PE-25HP PUMP

## Product Specification Sheet

### DESCRIPTION

- Pure Effect's PE-25HP-PUMP is a close-coupled, end-suction pump. It is constructed of cast iron, with unique back pull-out design that permits access to the impeller without disturbing the piping.
- Ideal for applications requiring high performance, easy maintenance and moderate initial cost.

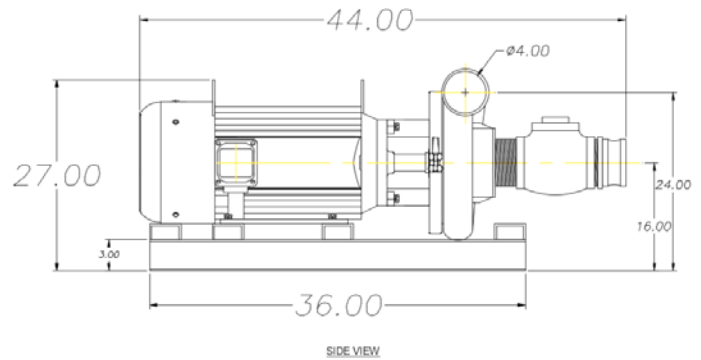

### FEATURES

- Four position discharge
- Premium-grade motors
- Motor bracket
- Maintenance-free shaft seal
- Replaceable slip-on shaft sleeve
- Replaceable bronze wear ring
- Superior impeller
- Heavy-duty voute case
- Multiple taps
- Durable finish

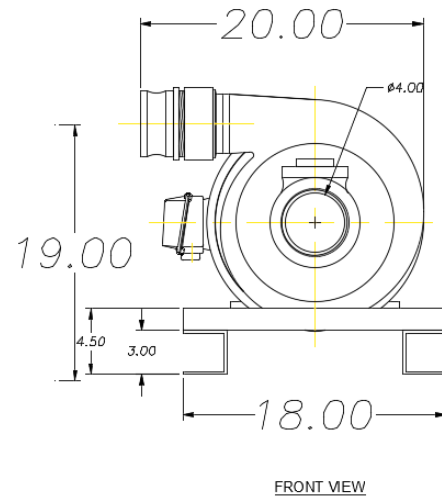

### TECHNICAL

- 25 HP pump
- Flow max: 650 gpm @ 100'TDH, 3" discharge
- Motor: TEFC, 3530 rpm @ 60hz
- Impeller dia: 7.25"
- Electrical: 3-phase, 230/460V, 60/30 amps

**Adhere to all applicable health & safety regulations when using this product.**