



PEV-1,000 CARBON VESSEL

Product Specification Sheet

DESCRIPTION

- Pure Effect's PEV-1,000 vapor phase carbon vessels are designed for the removal of contaminants from air streams, with flow ranges up to 1,000 cfm per unit and carbon capacity of 1,000 pounds.
- The PEV-1,000 vessels are designed and manufactured non-code. The materials used in construction are in accordance with standards established by local, state, and federal environmental standards.
- Typical applications for this line of filters include reduction of VOC concentrations, corrosive gases, toxic vapors and odor control.

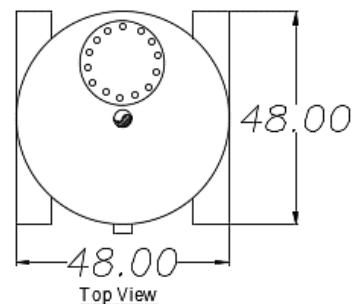

FEATURES

- Vessels are constructed of high grade carbon steel, with high solids epoxy lining and exterior paint of industrial enamel or urethane.
- Top access port of 18" dia. manway.
- Forklift tubes for portability.

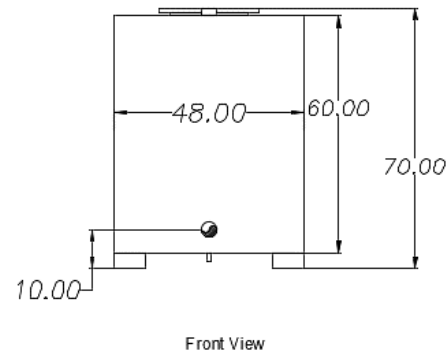

TECHNICAL

- Max fill: 1,000 lbs. granular activated carbon (GAC)
- Max pressure: 15 psi
- Design flow rate: 1,000 cfm
- Max operating temp: 140° F
- Overall dimensions: 48" (dia.) x 48" (width) x 70" (ht.)
- Inlet and outlet size: 4" or 6" NPT threaded
- Total volume: 62.5 ft³
- Shipping weight with carbon fill: 2,050 lbs.

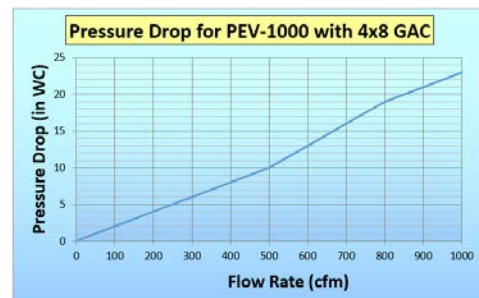

Adhere to all applicable health & safety regulations when using this product.