



# PEL-6,000 CARBON VESSEL

## Product Specification Sheet

### DESCRIPTION

- Pure Effect's PEL-6,000 liquid phase carbon vessels are designed for the removal of dissolved contaminants from liquid streams, with flow ranges up to 300 gpm per unit and carbon capacity of 6,000 pounds.
- The PEL-6,000 vessels are designed and manufactured non-code. The materials used in construction are in accordance with standards established by AWWA, FDA and EPA. These vessels are ideal for applications that require pressure ratings of less than 75 psi.
- Typical applications for this line of filters include municipal drinking water treatment, industrial wastewater treatment and groundwater remediation.

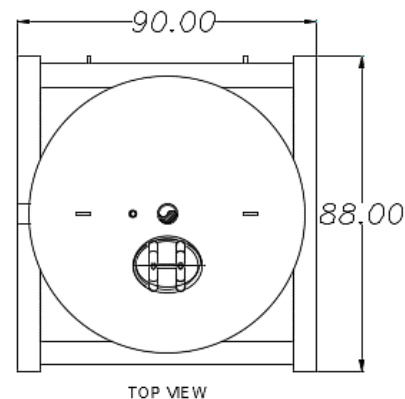

TOP VIEW

### FEATURES

- Vessels are constructed of high grade carbon steel, with high solids epoxy lining and exterior paint of industrial enamel.
- Top access port: 11"x16"
- Air relief valve.
- Pressure relief valve recommended.
- Forklift tubes and eyehooks for portability.

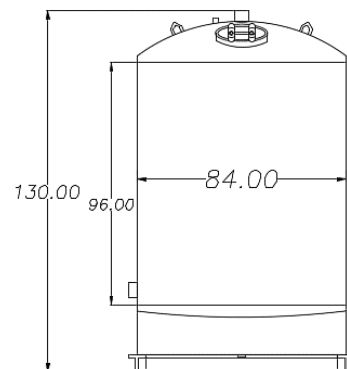

FRONT VIEW

### TECHNICAL

- Max fill: 6,000 lbs. granular activated carbon (GAC)
- Max pressure: 75 psi with pressure relief valve
- Design flow rate: 300 gpm
- Max operating temp: 140° F
- Overall dimensions: 84" (dia.) x 90" (width) x 130" (ht.)
- Inlet and outlet size: 4" or 6" NPT threaded
- Total volume: 345 ft<sup>3</sup>
- Shipping weight (empty): 3,300 lbs.

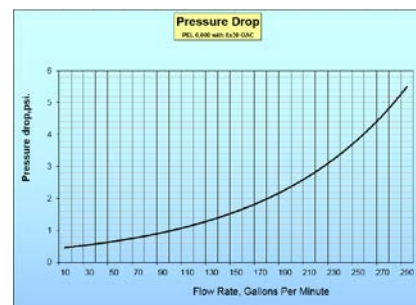

**Adhere to all applicable health & safety regulations when using this product.**