



PEL-5,000 CARBON VESSEL

Product Specification Sheet

DESCRIPTION

- Pure Effect's PEL-5,000 liquid phase carbon vessels are designed for the removal of dissolved contaminants from liquid streams, with flow ranges up to 250 gpm per unit and carbon capacity of 5,000 pounds.
- The PEL-5,000 vessels are designed and manufactured non-code. The materials used in construction are in accordance with standards established by AWWA, FDA and EPA. These vessels are ideal for applications that require pressure ratings of less than 75 psi.
- Typical applications for this line of filters include municipal drinking water treatment, industrial wastewater treatment and groundwater remediation.

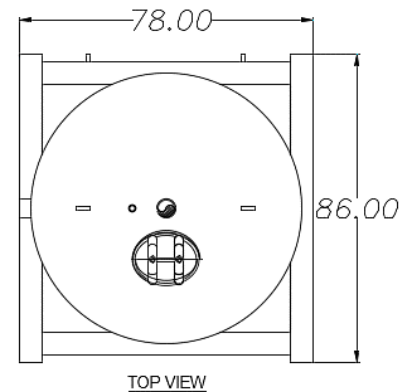

FEATURES

- Vessels are constructed of high grade carbon steel, with high solids epoxy lining and exterior paint of industrial enamel.
- Top access port: 12"x16"
- Air relief valve.
- Pressure relief valve recommended.
- Forklift tubes and eyehooks for portability.

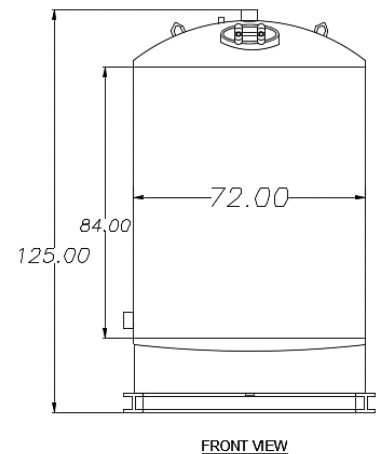

TECHNICAL

- Max fill: 5,000 lbs. granular activated carbon (GAC)
- Max pressure: 75 psi
- Design flow rate: 250 gpm
- Max operating temp: 120° F
- Overall dimensions: 80" (dia.) x 72" (width) x 125" (ht.)
- Inlet and outlet size: 4" or 6" NPT threaded
- Total volume: 200 ft³
- Shipping weight (empty): 4,500 lbs.

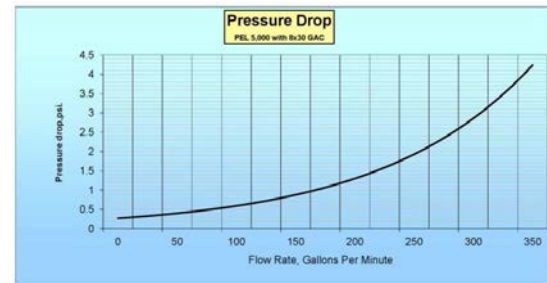

Adhere to all applicable health & safety regulations when using this product.