

Aircraft Maintenance and Engine Access Stand 07-12

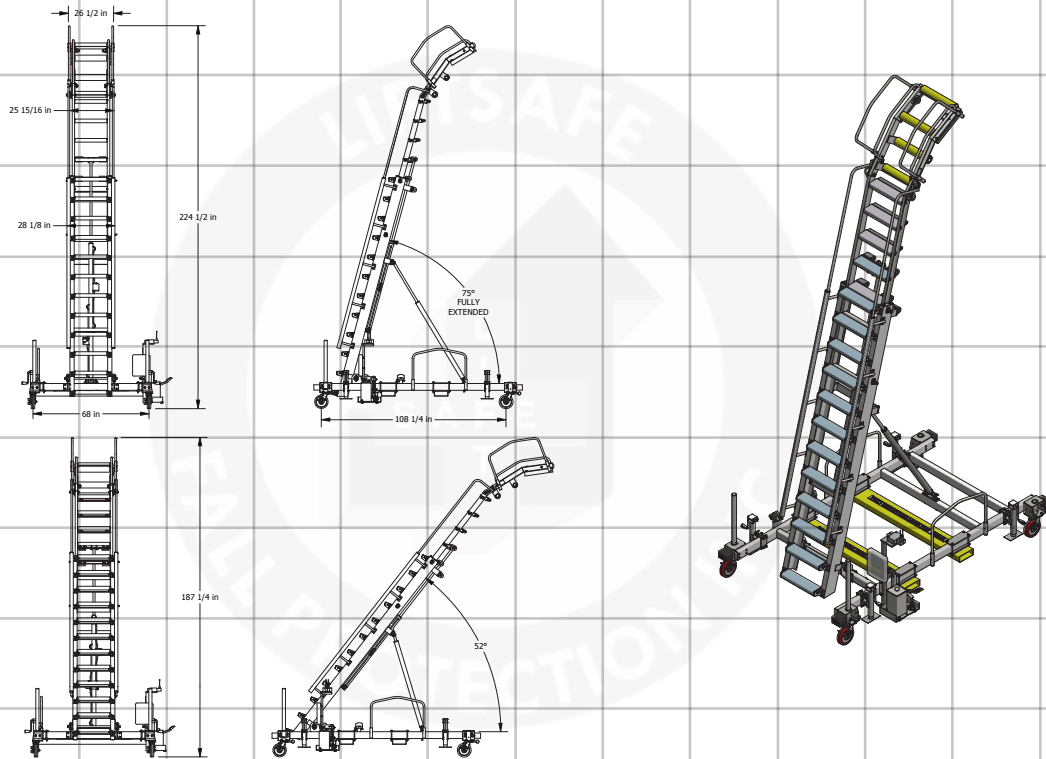

Technical Specifications

#	PART NUMBER. DF071554-07-12		DESIGNED FOR. Engine Access		MOVEMENT. 1 Person		Padding Material. Equipped
	ANGLES. 52 - 75 Degrees		AIRCRAFT TYPE. B777X & 777 Legacy		TOWING SPEED. 10 KPH/ 6 MPH		SHIPPING INFO (DIMS). 88" x 52" x 108 1/4" x 1,540 lbs
	HEIGHT. Low: 187 1/4" High: 224 1/2"		NUMBER OF USERS. 1 User		MATERIAL TYPE: LADDER. Aluminum		CASTER DETAILS. 10" With Brakes & Swivel
	FOOT PRINT. 68" x 108 1/4"		WEIGHT CAPACITY. 150 kg/330 lbs		MATERIAL TYPE: FRAME. Aluminum		CERTIFICATIONS. ANSI-ASC A14.7, BS EN 131.7 & CE
	CONTROLS. Hydraulic Foot Pump		Fully Extended. Ladder: 57 Strokes Tilt: 23 Strokes		FINISH. Powder Coated Finish		FALL RESTRAINT ANCHOR POINTS. Equipped

Stand Description

This stand was specifically designed for the B777X. We use anti-fatigue ladder rungs rather than narrow ladder rungs to ensure comfort when using the stands to change LRU'S, adjust components or connect/disconnect engines and nacelles this stand was also designed to provide access to the GE-90 powered 777 Legacy PDOS (powered door opening system). Design improvements include a lighter stand utilizing a smaller footprint and greater geometry for optimum usage.

The height and angle adjustments on this stand allow for diverse angle and height changes frequently required when servicing aircraft. The unit contains extensive aluminum construction for easy movement and a corrosion-resistant powder coat finish for longevity.

The stand facilitates safe access to nose cowls, fan cowls and pylon disconnect zones on PW, GE and RR engines, providing a safe working solution to many of the traditionally difficult under-cowling maintenance locations. The unit is also designed to safely access the same points outside of cowling, specifically forward and aft pylon service points. The hard to reach refuel panels and under-wing areas are also accessible using this product.

For increased safety and ease of mobility, the stand has optional accessories which can be added. They include 4 corner-leveling jacks, fold away tow bars and lift truck fork pockets. The stand is designed and tested in accordance with ANSI-ASC A14.7 and BS EN 131.7 and includes CE Certification.

Accessories

ACCESSORY	PART NUMBER	DESCRIPTION
Air Powered Pump	DF-Stand-Air-Pump	Optional air pump instead of the manual hydraulic pump system.
Fork Pockets	DF071554-07-Fork-Pockets	These fork pocket additions will enable you to quickly and easily move your stand.
Jacks	DF071554-07-Leveling-Jacks	This set of 4 leveling jacks and attachment plates will allow you to secure your stand.
Platform Adaptor	DF071554-Platform-Adaptor	Plugin platform in place of the curved section on all current engine stands.
Tow Bar	DF071554-07-Tow-Bar	Quickly and efficiently move your stand with the addition of a tow bar attachment.
Utilities Package	DF-Stand-Utilities-Package	Adds shop air and electrical power user service package to a unit.

