

	INSP.	
	FAB.	
SIGNATURE		DATE

REVISION HISTORY			
REV	DESCRIPTION	DATE	APPROVED
1.0	ISSUED FOR PRODUCTION	7/28/2017	C.R.

ROUTING FOR V02890		
OP	OPERATION	COMPLETED
OP 10	ASSEMBLY	
OP 20	N/A	
OP 30	N/A	
OP 40	N/A	
OP 50	N/A	
LAST OP	ASSEMBLY	

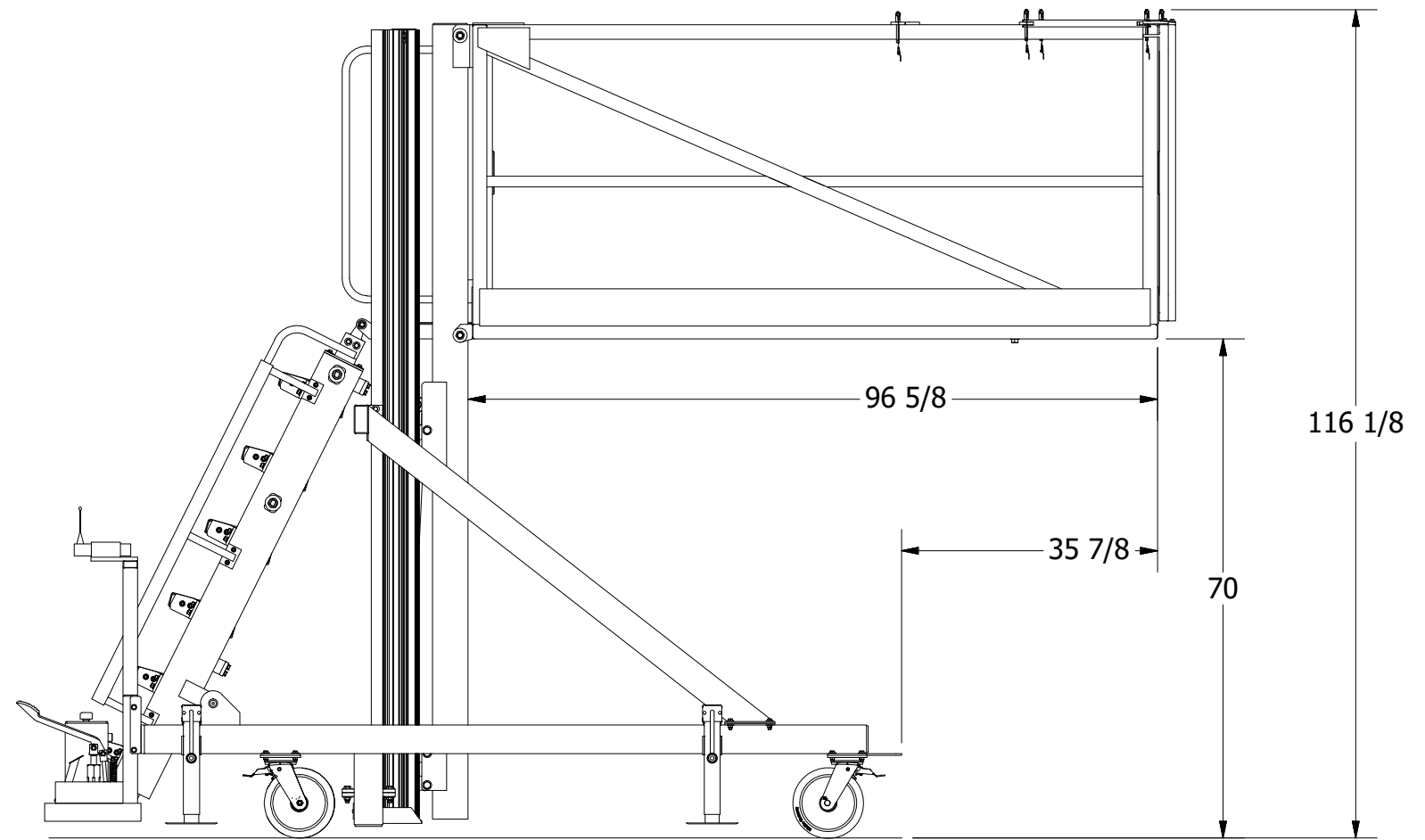
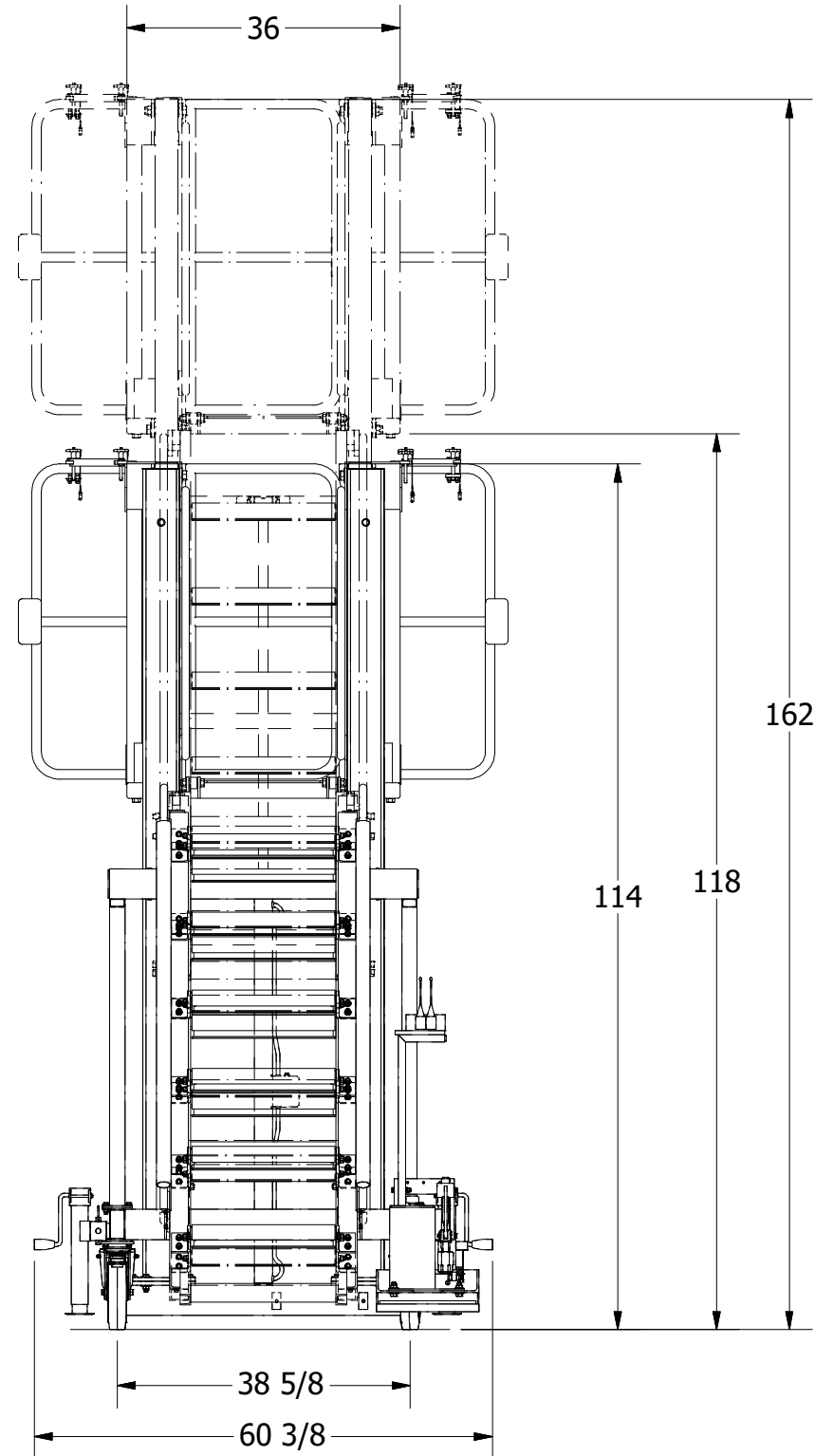

- GENERAL NOTES:
- 1) ALL STRUCTURAL STEEL SECTIONS SHALL CONFORM TO CSA G40.21-50W
 - 2) ALL STEEL PLATE AND BAR SHALL CONFORM TO CSA G40.21-44W
 - 3) ALL WELDING SHALL CONFORM TO CSA W59 AND BE UNDERTAKEN BY A WELDER FULLY APPROVED BY THE CANADIAN WELDING BUREAU TO CSA W47 DIVISION
 - 4) ALL WELDS TO BE SMOOTH AND FREE OF BURRS
 - 5) ALL WELDS TO BE 1/4" CONTINUOUS FILLET OR 1/4" EFFECTIVE THROAT FLARE BEVEL U.N.O.

THIS DRAWING AND THE INTELLECTUAL INFORMATION ON THIS DRAWING ARE THE PROPERTY OF LIFSAFE ENGINEERING & SERVICE GROUP INC. AND MAY NOT BE REPRODUCED OR USED IN ANY MANNER WITHOUT OUR WRITTEN CONSENT

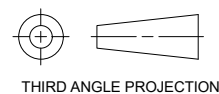

Tolerance Unless Noted Otherwise				
ANGLE	FRACTION	DECIMAL PLACES	INCHES	MILLIMETRES
± 1/2°	± 1/16	.XXX	± .005	± 0.1
		.XX	± .010	± 0.3
		.X	± .020	± 0.5

Part No. V02890		LIFSAFE ENGINEERING & SERVICE GROUP INC.	
Materials.		www.liftsafeinspections.com T. (519) 896-2430/1-800-977-2005, Email: info@liftsafeinspections.com F. (519) 896-2085	
Work Order No.	Customer & Location: GM Engine Plant St Catharines, ON		Project: GM CUSTOM MAINTENANCE STAND
Next Assembly.	Checked By: C.R.	Date: 8/2/2017	Description: TOP PLATFORM WITH TOP STAIRS ASSEMBLY
Designed By: G.R.	Date: 8/2/2017	SIZE: B	SCALE: N.T.S
Drawn By: G.R.	Date: 8/2/2017	SHEET 1 OF 2	
			DWG NO: V02890
			REV 1.0