

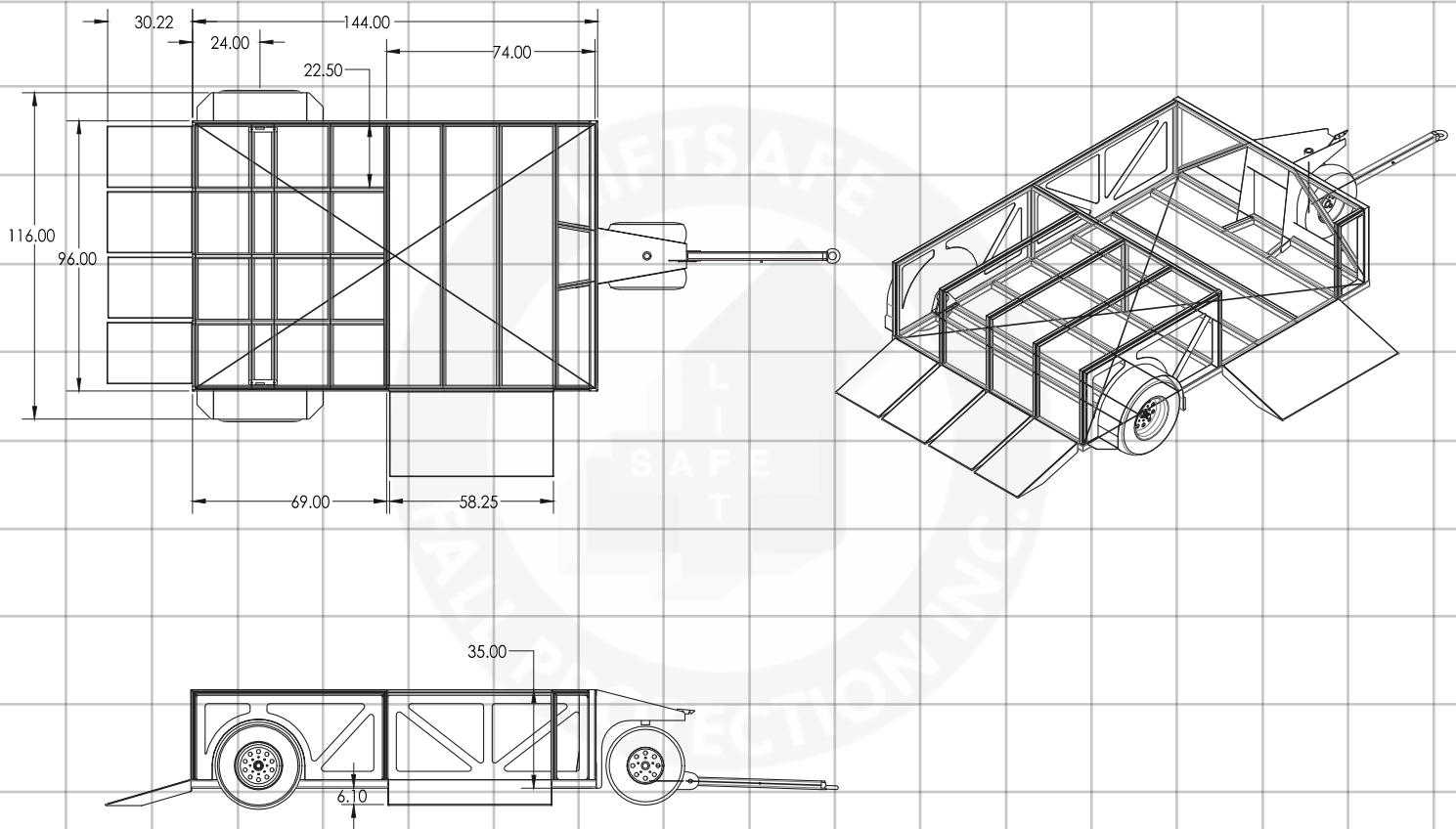















# Tire Trailers



## Technical Specifications

#	<b>PART NUMBER.</b> DF081002		<b>DESIGNED FOR.</b> Transports Wheel & Break Assemblies		<b>MOVEMENT.</b> Pintle, Towed		<b>Padding Material.</b> As Required
	<b>HEIGHT.</b> 5' 3/4"		<b>AIRCRAFT TYPE.</b> All Aircraft Types.		<b>MATERIAL TYPE: STRUCTURE.</b> Steel or Aluminum		<b>SHIPPING INFO (DIMS).</b> Contact Us
	<b>WIDTH.</b> 116"		<b>WEIGHT CAPACITY.</b> 1134 kg/2,500 lbs		<b>MATERIAL TYPE: RAMPS.</b> Steel or Aluminum		<b>CASTER DETAILS.</b> 15" or 16" Wheels Based on Customer Requirements
	<b>Configuration.</b> Based upon Customer Requirements		<b>TOWING SPEED.</b> 50 KPH / 31 MPH		<b>FINISH.</b> Powder Coated Finish		<b>FALL RESTRAINT ANCHOR POINTS.</b> Not Equipped

## Trailer Description

The Aviation Tire Trailer was designed to provide safe and quick transportation of aircraft wheel assemblies, brakes and required tooling while maintaining the storage requirements of regulatory bodies (EASA, TC, FAA). Operational at both commercial and private/business jet operators, the Aviation Tire Trailer can be configured to carry B777 tires along with associated tire change jacks and tools, or a full ship set of tires for a CL-605.

We also offer the trailer configured for Nitrogen and/or Oxygen servicing.

Liftsafe Fall Protection has designed numerous sizes of standard and custom Tire Trailers based on operational needs. The low profile design and lightweight swing gates ensure safety of maintenance staff during use. Foam filled tires are available upon request. Our Professional Engineers will work with you to determine what size Aviation Tire Trailer works best within your operation.

Our Professional Engineers can design custom models based on your specific requirements.

What Our Customers Are Saying About Our Equipment:

*"We find that Liftsafe is more than willing to work with us in creating safe, economical and multi-purpose designed equipment, tailored to our needs."*

## Accessories

ACCESSORY	DESCRIPTION
Foam Filled Tires	Help ensure the longevity of your tire trailer with the addition of these tires.
Solid Tires	Ensure that your tire trailer is always ready when you need it with these tires.
Nitrogen Bottle Holders	These bottle holders will help ensure everything stays in place when moved.
Brake Lifting Hoist	This ergonomic system will help optimize the time spent moving parts.
Fully Covered	Rain or shine this addition will make sure everything inside the trailer is kept dry.
Tool Boxes	These tool boxes will help to ensure that all tools are kept in place.
Surge Braking System	When you need to stop, ensure that your tire trailer will with this system.



NOTE: Examples of standard design.