

CABIN ACCESS STAND
OPERATION POSITION

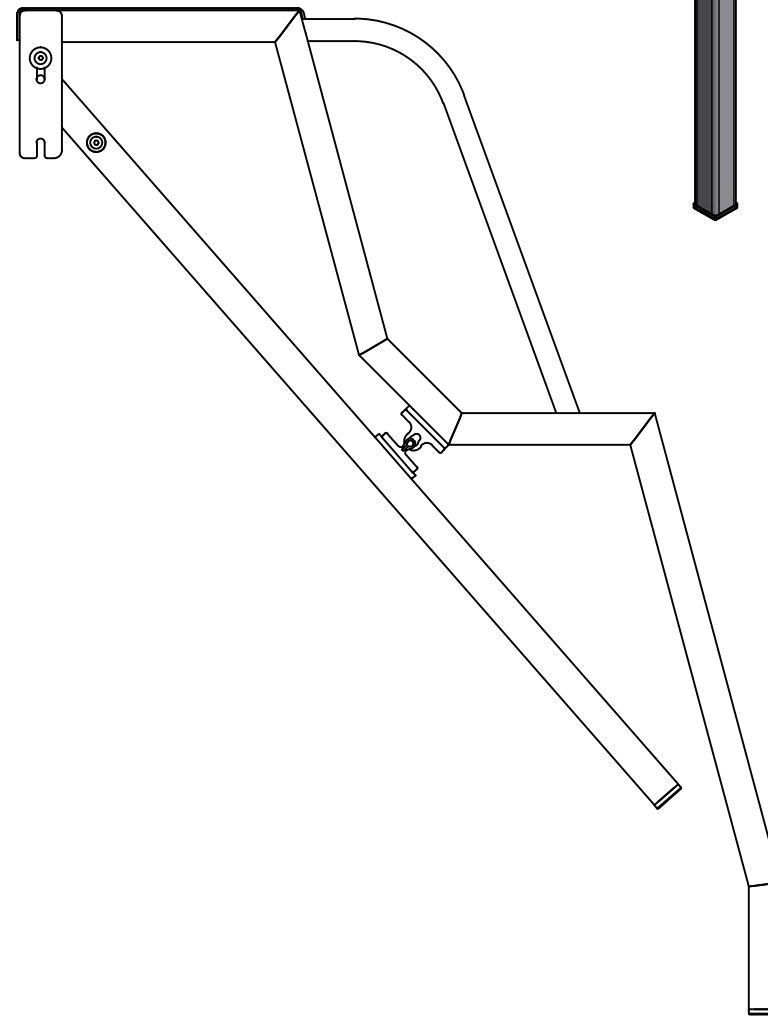

CABIN ACCESS STAND
COLLAPSED POSITION

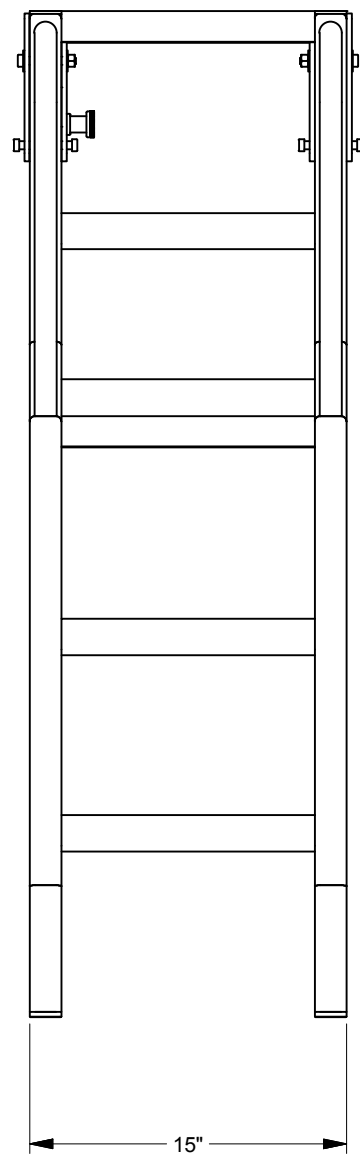

CABIN ACCESS STAND