



Maintenance and Operation Manual for Landing Gear Access Stand

 DF071592 – 03

Table of Contents

<u>Section</u>	<u>Page Number</u>
1.0 Standards	3
2.0 Electrical Hazard	4
3.0 Safety Precautions	5
4.0 Inspections	7
5.0 First Use Instructions	8
6.0 Maintenance, Inspection and Service	8
7.0 Replacement Parts List	12
8.0 Regular Operation Procedure	14
9.0 Notes	16



1.0 Standards

Tested in general accordance with the applicable requirements of

- DIN EN 131 – 2 : 2012
- BS EN 131 – 7 : 2013
- ANSI – ASC A14.7 – 20 – 2011

The best insurance against an accident is a careful, qualified operator. Most accidents are caused by the failure of individuals to follow simple and fundamental safety rules and precautions. Use common sense when operating a Landing Gear Access Stand.

You, as a careful operator, are the best insurance against an accident. Therefore, proper usage of this Landing Gear Access Stand is mandatory. The following pages of this manual should be read and understood completely before operating the mobile ladder stand.

Common sense dictates the use of protective clothing when working on or near machinery. Use appropriate safety devices to protect your eyes, ears, hands, feet and body.

Any modifications from the original design are strictly forbidden without written permission from Liftsafe Engineering and Service Group Inc.





2.0 Electrocutation Hazard

This Landing Gear Access Stand is not electrically insulated. Maintain a Minimum Safe Approach Distance (MSAD) from energized power lines and parts as listed below. The operator must allow for the ladder to sway, rock or sag. This Landing Gear Access Stand does not provide protection from contact with or proximity to an electrically charged conductor.

DO NOT Use the Landing Gear Access Stand as a ground for Welding.

DO NOT the Operate Landing Gear Access Stand during lightning or storms.

Avoid Power Lines

Minimum Safe Approach Distance

Voltage Range (Phase to Phase)	Minimum Safe Approach Distance (Feet)	CE Guidance Note “Avoidance of danger from overhead lines”
0 to 300V	Avoid Contact	Adhere strictly to the governmental rulings and regulations applicable to your country.
Over 300 v to 50KV	10	
Over 50KV to 200KV	15	
Over 200KV to 350KV	20	
Over 350KV to 500KV	25	
Over 500KV to 750KV	35	
Over 750KV to 1000KV	45	



3.0 Safety Precautions

Know and understand the Safety Precautions before use!

Failure to heed the following safety precautions could result in tip over, falling, crushing or other hazards leading to death or serious injury.

- ☞ KNOW all national, state or territorial/provincial and local rules which apply to your mobile ladder stand and jobsite.
- ☞ WEAR all the protective clothing and personal safety devices issued to you or called for by job conditions.
- ☞ DO NOT wear loose clothing, dangling neckties, scarves, rings, wristwatches or other jewelry while operating this ladder.
- ☞ AVOID entanglement with ropes, cords or hoses.
- ☞ AVOID falling. Stay within the boundaries of the handrails. Overreaching, while on the ladder, could cause instability and result in a fall. Always keep the unit in close proximity to work. Descend and relocate the unit to prevent overreach.
- ☞ DO NOT raise the mobile ladder stand in windy or gusty conditions.
- ☞ DO NOT increase the lateral surface area of the Landing Gear Access Stand. Increasing the area exposed to the wind will decrease Landing Gear Access Stand stability.
- ☞ DO NOT move or elevate the mobile ladder stand if it is not on a firm level surface. Do not move near depressions or holes of any type, loading docks, debris, drop-offs and surfaces that may affect the stability of the Landing Gear Access Stand.
- ☞ DO NOT operate on surfaces not capable of holding the weight of the Landing Gear Access Stand including the rated load, e.g. covers, drains, and trenches.
- ☞ DO NOT operate a Landing Gear Access Stand that has extensions, ladders, scaffolding or other devices mounted on it to increase its size or work height. It is prohibited.
- ☞ DO NOT exert side forces on Landing Gear Access Stand.
- ☞ DO NOT use the Landing Gear Access Stand as a crane. It is prohibited.
- ☞ DO NOT sit, stand or climb on any part of the Landing Gear Access Stand except the intended ladder rungs. It is prohibited.

- ☞ DO NOT raise or lower the Landing Gear Access Stand with a person or equipment on the ladder. It is prohibited.
- ☞ DO NOT move the Landing Gear Access Stand with a person or equipment on the ladder. It is prohibited.
- ☞ ENSURE the ladder is only raised or lowered from an operator standing on the ground.
- ☞ BE AWARE of overhead obstructions or other possible hazards around the Landing Gear Access Stand when moving or lifting.
- ☞ DO NOT use the Landing Gear Access Stand while the mobile ladder stand is on a truck, fork lift or other device or vehicle.
- ☞ BE AWARE of crushing hazards. Keep all body parts away from moving parts.
- ☞ DO NOT lower the ladder unless the area below is clear of personnel and obstructions.
- ☞ BE AWARE of blind spots when operating the mobile ladder stand.
- ☞ STUNTS and horseplay are prohibited.
- ☞ ENSURE all wheel brakes are locked, outrigger jacks are down (if equipped) and Landing Gear Access Stand is level prior to climbing ladder.
- ☞ DO NOT exceed the rated capacity of the Landing Gear Access Stand.
- ☞ DO NOT position the Landing Gear Access Stand against another object to steady the ladder.

Ascending and descending the ladder shall only be done using three points of contact.

- ☞ Use only equipped ladder for ascending and descending.
- ☞ Do use three points of contact ascending and descending the ladder. Face the ladder when entering and exiting.
- ☞ Three points of contact means that two hands and one foot or one hand and two feet are in contact with the ladder or the ground at all times during ascending or descending.

An operator should not use any mobile ladder stand that:

- ☞ Does not appear to be working properly.
- ☞ Has been damaged or appears to have worn or missing parts.
- ☞ Has alterations or modifications not approved by the manufacturer.
- ☞ Has safety devices which have been altered or disabled.
- ☞ Has been tagged or blocked out for non-use or repair.

Failure to avoid these hazards could result in death or serious injury



4.0 Inspections

4.1 Job Site Inspection

- 🔧 Do not use in hazardous locations.
- 🔧 Perform a thorough jobsite inspection prior to operating the Landing Gear Access Stand, to identify potential hazards in your work area.
- 🔧 Be aware of moving equipment in the area. Take appropriate actions to avoid collision.

4.2 Maintenance and Inspection Schedule

The actual operating environment of the landing gear access stand governs the use of the maintenance schedule. The inspection points covered in Table 1.2 Maintenance and Inspection Checklist indicates the areas of the Landing Gear Access Stand to be maintained or inspected and at what intervals the maintenance and inspections are to be performed.

4.3 Owner's Annual Inspection Record

It is the responsibility of the owner to arrange quarterly and annual inspections of the Landing Gear Access Stand. Table 1.1 Owner's Annual Inspection Record is to be used for recording the date of the inspection, owner's name, and the person responsible for the inspection of the Landing Gear Access Stand.

4.4 Replacement Parts

Use only original replacement parts. Parts such as wheels, handrails, etc. with weight and dimensions different from original parts will affect stability of the Landing Gear Access Stand and must not be used without manufacturer's consent.



5.0 First Use Instructions

Inspect all components of the landing gear access ladder stand prior to assembling and report any missing or damaged components to Liftsafe Engineering & Service Group Inc.

- 🔧 The Landing Gear Access Stand is typically shipped fully assembled, though sometimes this may not be the case, in these circumstances separate instructions regarding assembly will be included.
- 🔧 Check all hardware on the Landing Gear Access Stand to ensure nothing has become loose during shipping.
- 🔧 Complete a start-up annual inspection and full function test prior to first use (refer to table 1.2).

6.0 Maintenance, Inspection and Service

Any unit that is damaged or not operating properly must be immediately tagged and removed from service until proper repairs are completed.

6.1 Maintenance and Service Safety Tips

- 🔧 Maintenance and repair should only be performed by personnel who are trained and qualified to service this Landing Gear Access Stand.
- 🔧 All maintenance and service procedures should be performed in a well-lit and well ventilated area.
- 🔧 Anyone operating or servicing this Landing Gear Access Stand must read and completely understand all operating instructions and safety hazards in this manual.
- 🔧 All tools, supports and lifting equipment to be used must be of proper rated load and in good working order before any service work begins. Work area should be kept clean and free of debris to avoid contaminating components while servicing.
- 🔧 All service personnel must be familiar with employer and governmental regulations that apply to servicing this type of equipment.
- 🔧 Keep sparks and flames away from all flammable or combustible materials.
- 🔧 Properly dispose of all waste material such as lubricants, rags, and old parts according to the relative law provisions obtaining in the country.

6.2 Maintenance and Inspection

Death or injury can result if the Landing Gear Access Stand is not kept in good working order. Inspection and maintenance should be performed by competent personnel who are trained and qualified on maintenance of this landing gear access stand.

Failure to perform each procedure as presented and scheduled may cause death, serious injury or substantial damage.

NOTE: Preventive maintenance is the easiest and least expensive type of maintenance.

- 🔧 Unless otherwise specified, perform each maintenance procedure with the Landing Gear Access Stand in the following configuration:
- 🔧 Landing Gear Access Stand parked on a flat and level surface with wheel brakes engaged.
- 🔧 Repair any damaged or malfunction components before operating Landing Gear Access Stand.
- 🔧 Keep records on all inspections.

6.3 Maintenance Instructions

This manual consists of four schedules to be done for maintenance on a Landing Gear Access Stand. Inspection schedule frequency is shown below:

Inspection Schedule

Daily	A
Frequently	A + B
Annually	A + B + C
Bi-Annually	A + B + C + D

- 🔧 Make copies of the maintenance and inspection checklist to be used for each inspection.
- 🔧 Check the schedule on the checklist for the type of inspection to be performed.
- 🔧 Place a check in the appropriate box after each inspection procedure is completed.
- 🔧 Use the maintenance and inspection checklist to perform these inspections.
- 🔧 If any inspection receives a fail, tag and remove the Landing Gear Access Stand from service.



LEGEND		
P=PASS	F=FAIL	R=REPAIRED

Table 1.1 Owners Annual Inspection

Model Number:					Serial Number:				
Recording Date	1	2	3	4	5	6	7	8	9
Recording Year									
Owners Name									
Inspected By									

Table 1.2 Maintenance and Inspection Checklist

If any Landing Gear Access Stand component(s) has been repaired, an inspection must be performed again before removing the tag. Place a check in the repair column.

Serial Number:	Operators Name: (Please Print)
Model Number:	
Date:	Operator's Signature:
Time:	

As each item is inspected, write the appropriate grade in the box.

P=PASS

F=FAIL

R=REPAIRED

A: Perform Visual and Daily Maintenance Inspections & Functions Test

B: Perform scheduled Maintenance Inspection every three months based on regular

C: Perform scheduled Maintenance Inspection every year

Schedule		P	F	R
Inspection Point				
Labels	A+B+C			
Wheel Brakes	A+B+C			
Caster Swivel Locks	A+B+C			
Rails	A+B+C			
Fall Arrest Anchor Points	A+B+C			
Oil Level	A+B+C			
Foot Pump	A+B+C			
Ladder Structure	A+B+C			
Base Frame Structure	A+B+C			
Hand Rails	A+B+C			
Bumpers	A+B+C			
Hardware	A+B+C			
Directional Control Valve	A+B+C			
Function Test	A+B+C			

NOTE: Make a copy of this page

7.0 Replacement Parts List

Item	Part Number	QTY	Description
1	V00584	2	TIE OFF
2	V00616	4	ALUMINUM TREAD WELDMENT
3	V00643	1	48" STROKE CYL
4	V01092	2	6" CASTER
5	V01094	8	ROLLER CARRIAGE
6	V01106	1	TRACK ROLLER
7	V01108	4	1" SLIDE-ON GRIP HANDLE
8	V01115	2	GUIDE RAIL 24"
9	V01143	1	FOAM PRP-190 2" I.D. x 3 1/2" O.D. ATTACS
10	V01144	2	YELLOW LADDER BUMPER
11	V01152	8	ALUMINUM TREAD WELDMENT
12	V01213	2	10" CASTER
13	V01286	1	TRACK ROLLER McMaster-Carr
14	V01657	1	Directional Control Valve
15	V01658	1	Foot Operated Pump
16	V01814	4	7/8"-9 S.S. THREADED ROD
17	V01815	4	3 1/2" O.D. BLACK ACETAL

7.1 Approved List of Hydraulic Fluids and Lubricants

Fluids:

☞ AW32 Hydraulic Oil

Lubricants:

☞ N/A

Fall Arrest Anchor Points

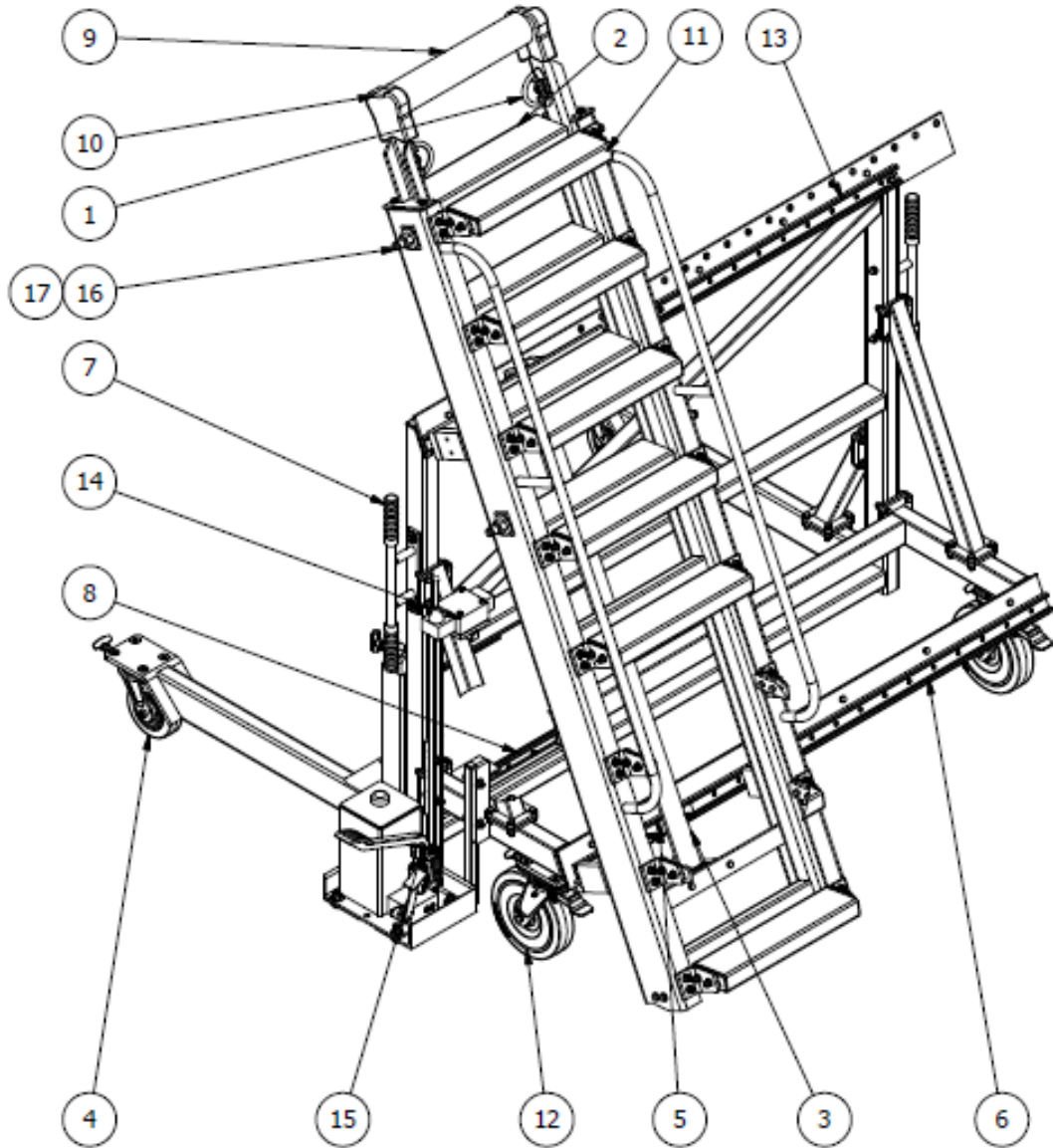

8.0 Regular Operation Procedure

8.1 Regular Operation Procedure

- 🔧 Ensure stand free of tools, equipment, and personnel
- 🔧 Ensure safety of Landing Gear Access Stand
- 🔧 Ensure safety of operating area
- 🔧 Locate Landing Gear Access Stand in operating area
- 🔧 Position Landing Gear Access Stand leg by pulling pin and slide into position. Release pull pin into locking hole. (Figure 1)
- 🔧 Disengage and stow tow bar (IF Equipped)
- 🔧 Engage wheel locks (Figure 2)
- 🔧 Position ladder on rail slider by pulling pull pin out and sliding into position. Release pull pin into locking hole. (Figure 3)
- 🔧 Keep hands/feet clear of all moving parts during operation
- 🔧 Hold black hydraulic lever either towards the ladder to raise the ladder or pull back towards the operator to lower the ladder (Figure 4)
- 🔧 Begin to pump using foot lever to either raise or lower (Figure 4)
- 🔧 Secure one's self using fall arrest Anchors (Figure 5)
- 🔧 Do not raise or lower with someone on ladder



Figure 1



Figure 2



Figure 3



Figure 4

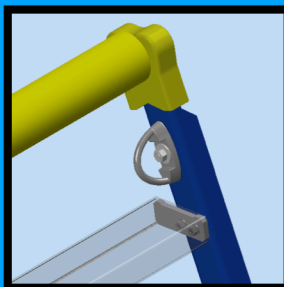

Image of 1 of 2 Anchor points

Figure 5

8.2 After Use

- 🔧 Ensure Landing Gear Stand is free of all equipment, tools, and personnel
- 🔧 Ensure area below and around Stand is clear of obstructions
- 🔧 Fully Retract Extending Ladder
- 🔧 Disengage wheel Locks
- 🔧 Store Landing Gear Stand in a safe, dry location

8.3 Tow Bar (If Equipped)

- 🔧 Do not tow while ladder raised
- 🔧 Do not tow while tools, equipment, or personnel are on the Landing Gear Access Stand
- 🔧 Do not tow over 10km/h (6mph)

Landing Gear Access Stand
Model# DF071592 – 03
Maintenance and Operation

9.0 Notes



Liftsafe Fall Protection

409 Harmony Road

Ayr, Ontario N0B 1E0

TF.: 1 (800) 977-2005

T.: (519) 896-2430

F.: (519) 896-2085

E.: info@liftsafeinspections.com

W.: www.fallsafetyolutions.com