

PLAN W/O LID

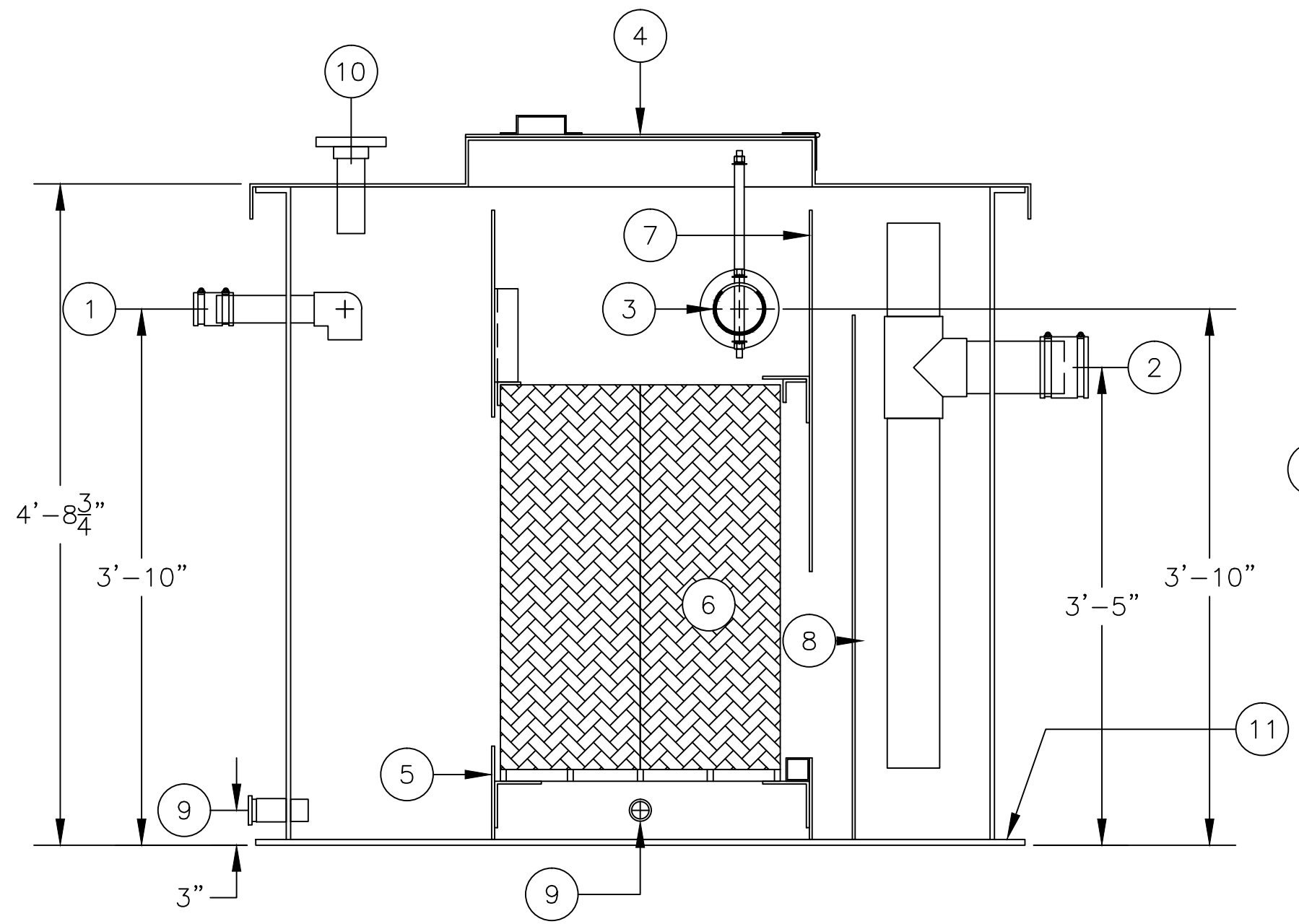

SECTION "A-A"

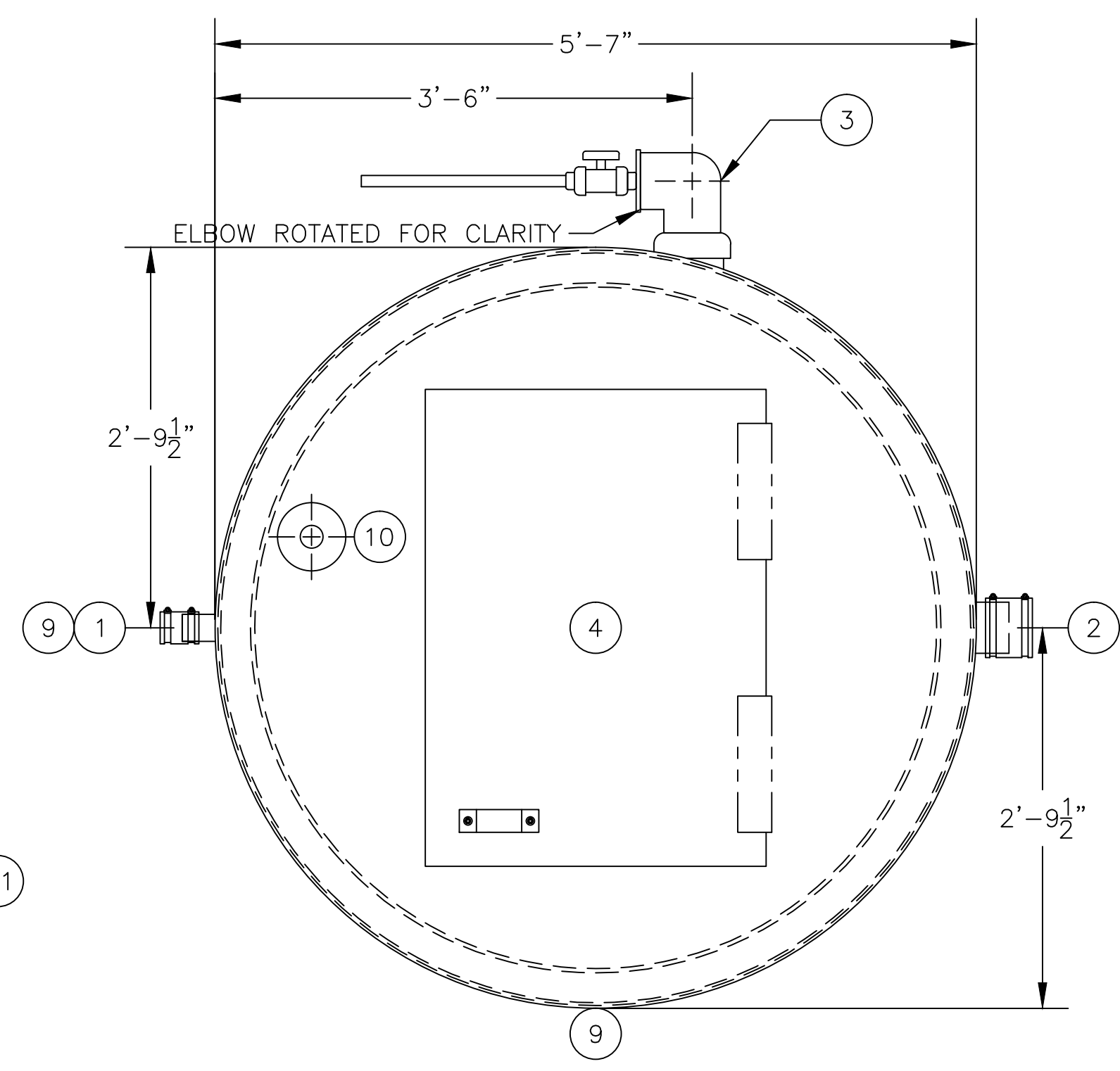

PLAN W/ LID

ASSEMBLY LIST

- ① 2"Ø INLET, PIPE STUB W/ FLEX CONNECTOR
- ② 4"Ø OUTLET, PIPE STUB W/ FLEX CONNECTOR
- ③ 4" ROTARY PIPE SKIMMER W/ OIL OUTLET
- ④ 3'-6" x 2'-6" MANWAY
- ⑤ INLET BAFFLE
- ⑥ COALESCING MEDIA
- ⑦ OIL RETENTION BAFFLE
- ⑧ WEIR WALL
- ⑨ 1 1/2"Ø DRAIN CPLG., FPT W/ PLUG(2 REQ'D.)
- ⑩ 2"Ø LEVEL SWITCH MTG. PROVISION, FLANGED
- ⑪ BOTTOM HOLD DOWN FLANGE

WEIGHTS & CAPACITIES

EMPTY WGT. APPROX.=450#
 OPERATING CAP.=544 GAL.
 OPERATING WGT.=4,840#
 NORMAL OIL CAP.=30 GAL.
 OIL SPILL CAP.=195 GAL.

MODEL: RA-F-50 G.P.M.	OWS JOB No. -	DRAWING No. 3S5028 FILE: RA-F-50 7/9/13	THIS DRAWING AND SPECIFICATION IS THE PROPERTY OF OWS TECHNOLOGIES 1109 25TH STREET WEST PALM BEACH, FL 33407. NO PARTS OR INFORMATION HEREIN SHALL BE REPRODUCED WITHOUT WRITTEN PERMISSION.	DRAWN BY: TMB CHECKED BY:
	SCALE: 1=12	DATE: 7/9/13	OIL WATER SEPARATOR TECHNOLOGIES, LLC 1109 25TH STREET W.P.B., FL. 33407	

