

PLAN W/O LID

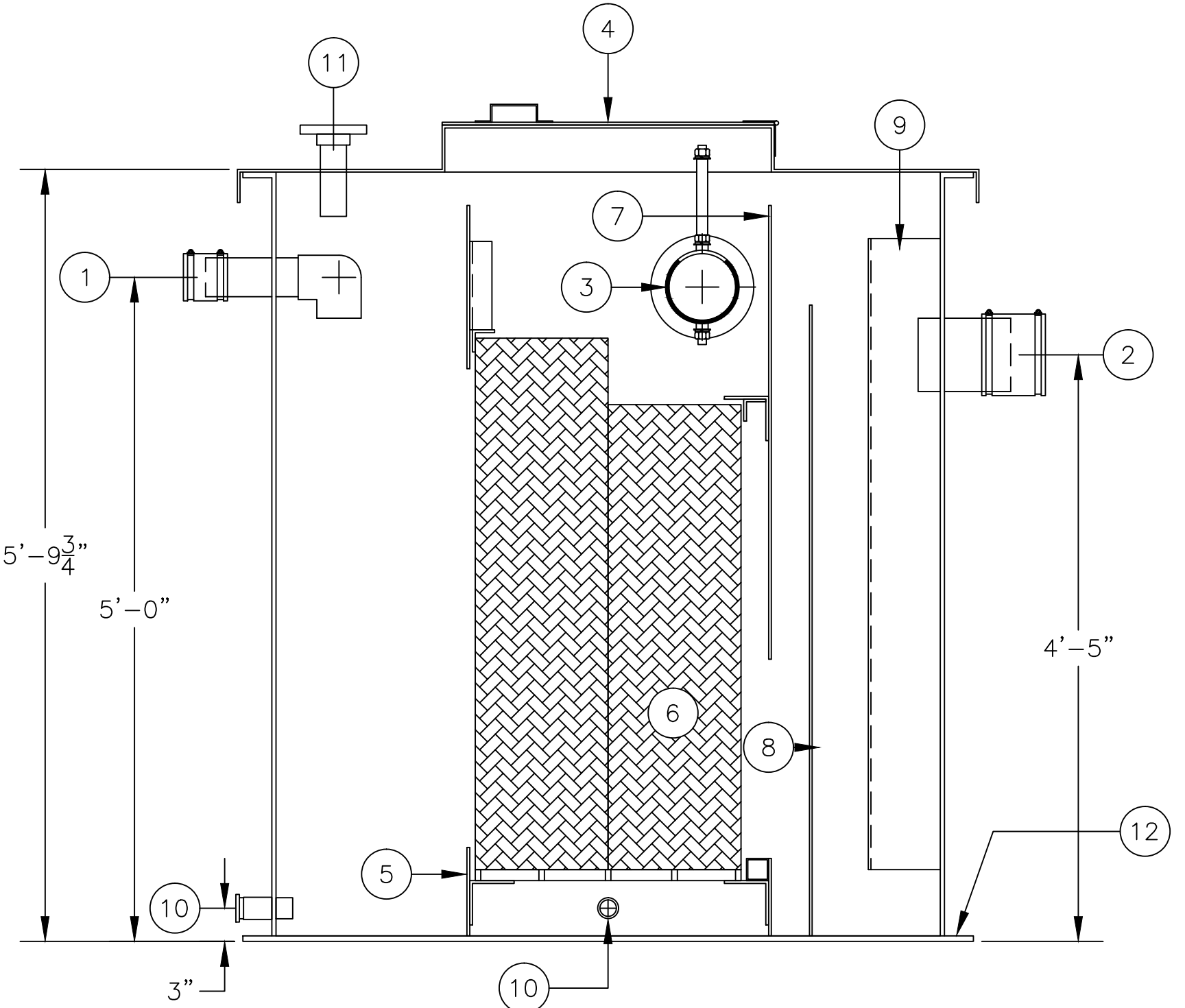

SECTION "A-A"

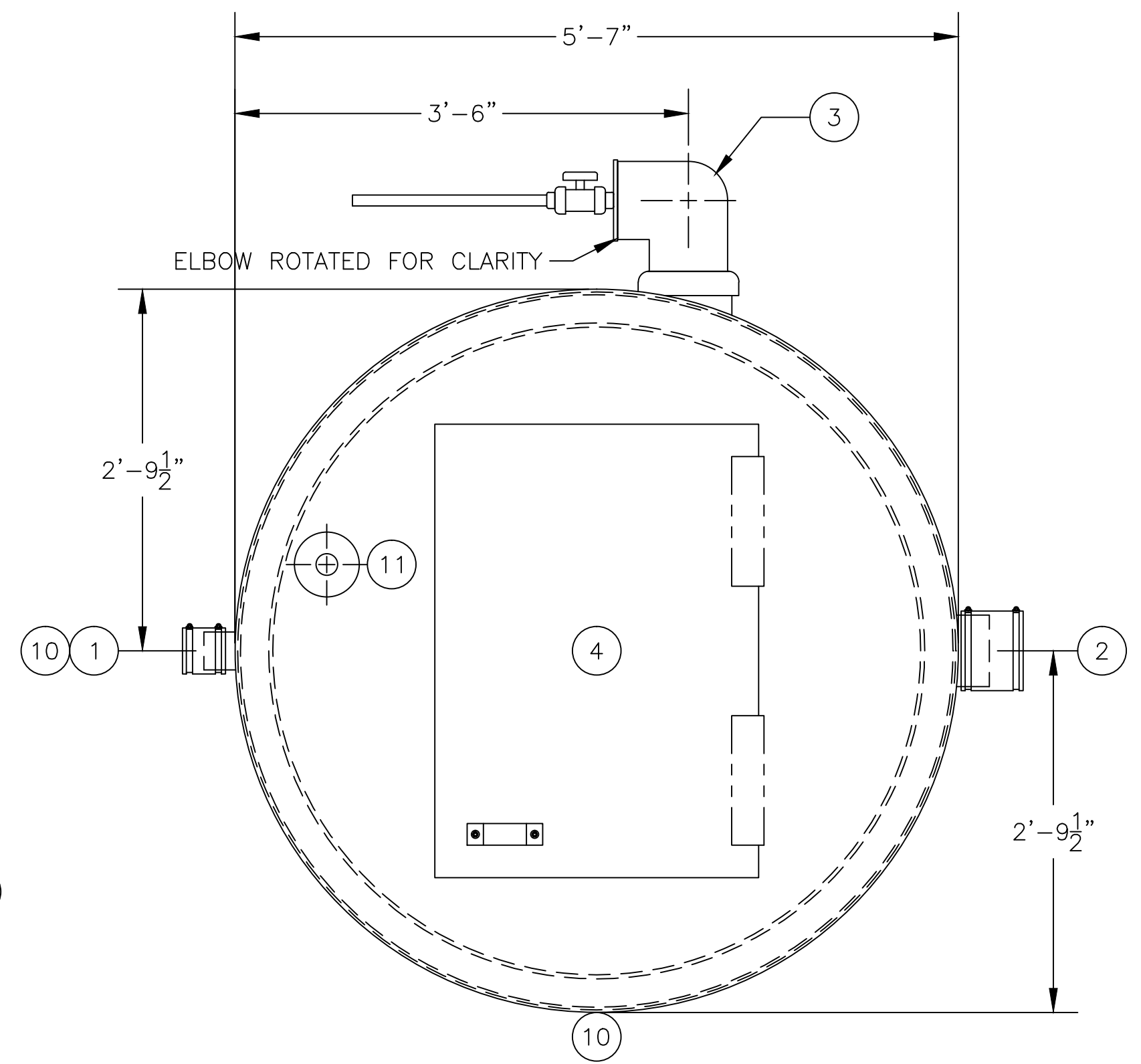

PLAN W/ LID

ASSEMBLY LIST

- ① 3"Ø INLET, PIPE STUB W/ FLEX CONNECTOR
- ② 6"Ø OUTLET, PIPE STUB W/ FLEX CONNECTOR
- ③ 6" ROTARY PIPE SKIMMER W/ OIL OUTLET
- ④ 3'-6" x 2'-6" MANWAY
- ⑤ INLET BAFFLE
- ⑥ COALESCING MEDIA
- ⑦ OIL RETENTION BAFFLE
- ⑧ WEIR WALL
- ⑨ VERTICAL OUTLET FLUME
- ⑩ 1 1/2"Ø DRAIN CPLG., FPT W/ PLUG(2 REQ'D.)
- ⑪ 2"Ø LEVEL SWITCH MTG. PROVISION, FLANGED
- ⑫ BOTTOM HOLD DOWN FLANGE

WEIGHTS & CAPACITIES

EMPTY WGT. APPROX.=500#
 OPERATING CAP.=690 GAL.
 OPERATING WGT.=6,240#
 NORMAL OIL CAP.=30 GAL.
 OIL SPILL CAP.=290 GAL.

MODEL: RA-F-100 G.P.M.	OWS JOB No. -	DRAWING No. 3S5029	DRAWN BY: TMB CHECKED BY:
	JOB: OWS TECHNOLOGIES	FILE: RA-F-100 7/9/13	DATE: 7/9/13



OIL WATER SEPARATOR
TECHNOLOGIES, LLC
 1109 25TH STREET W.P.B., FL. 33407