

PLAN

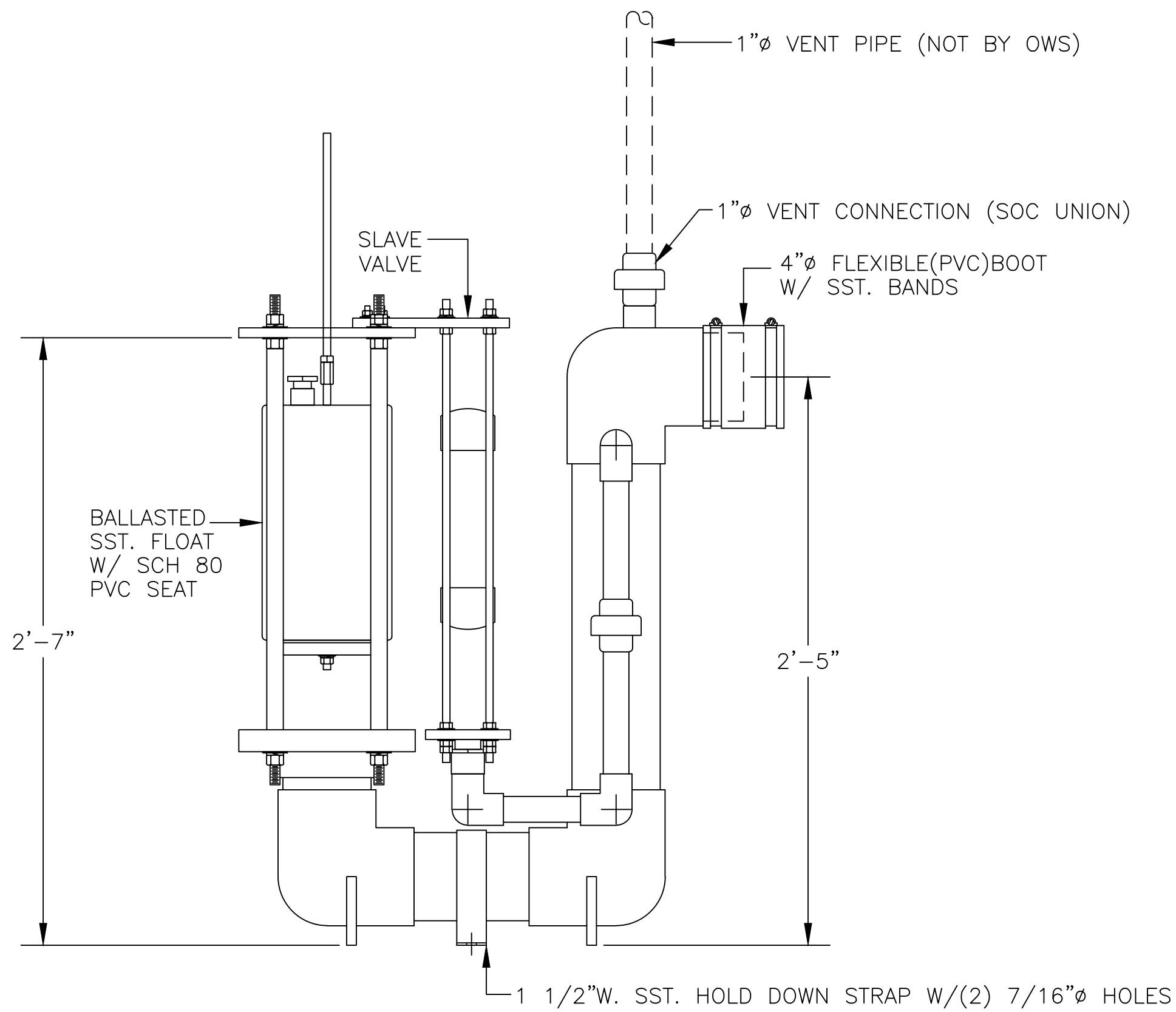

SIDE VIEW

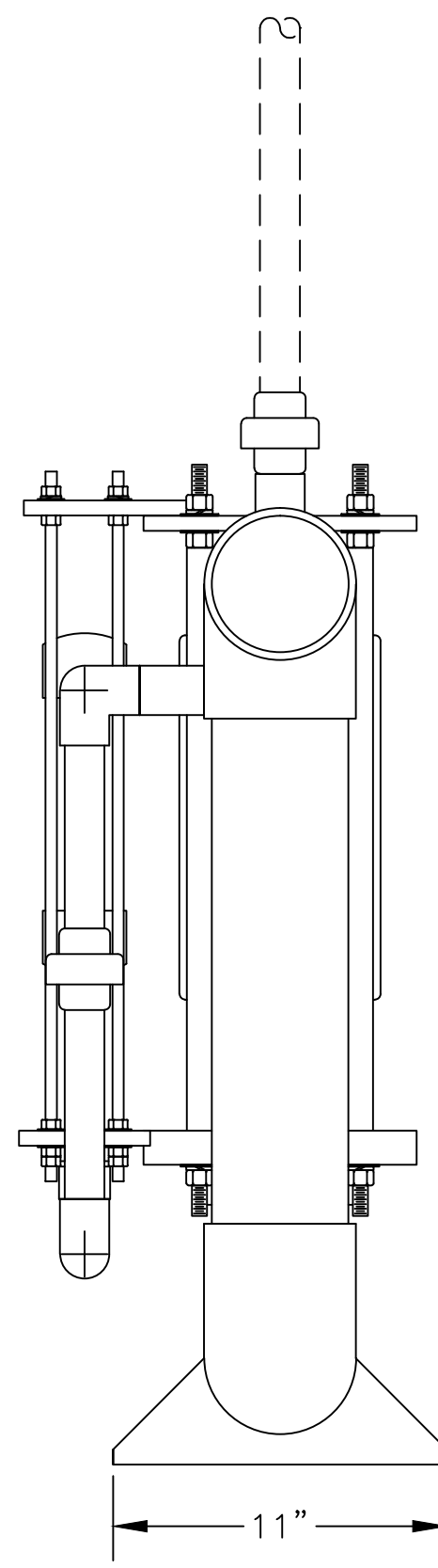

OUTLET END

IMPORTANT INFORMATION

COMPLETE STEP BY STEP INSTALLATION INSTRUCTIONS ARE PROVIDED WITH EACH VALVE TO INSURE PROPER OPERATION. SEE BULLETIN# 6.1 READING THE ENTIRE PROCEDURE BEFORE ATTEMPTING INSTALLATION WILL SAVE TIME & MONEY.

1. OUTLET PIPE STUB SHIPPED LOOSE.
2. FLEXIBLE OUTLET CONNECTION SHIPPED LOOSE.
3. HOLD DOWN STRAP IS SHIPPED LOOSE.
4. 1"Ø VENT PIPE TO BE SUPPLIED & INSTALLED BY CONTRACTOR. VENT PIPE MUST BE EXTENDED ABOVE MAXIMUM OIL LEVEL OR OUTSIDE OF OIL SUMP. OIL MAY BYPASS STOP VALVE IF VENT IS NOT INSTALLED PROPERLY.
5. VALVE VAULT MUST BE PRIMED WITH WATER & FLOAT OPENED PRIOR COMPLETION OF INSTALLATION.
6. MANUAL LIFTING CABLE HANDLE IS TO BE MOUNTED NEAR MANHOLE BY CONTRACTOR. DO NOT USE MANUAL LIFTING CABLE IF OIL IS PRESENT.

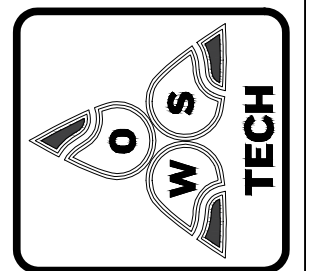

**OIL WATER SEPARATOR
TECHNOLOGIES, LLC**
1109 25TH STREET W.P.B., FL. 33407

OWS JOB No. -

MODEL:
OWS-OSV-4SV

DRAWING No. 3S5004
FILE: OSV-4SV 6/19/13

JOB:
OWS TECHNOLOGIES

DRAWN BY: TMB

THIS DRAWING AND SPECIFICATION IS THE PROPERTY OF OWS TECHNOLOGIES, 1109 25TH STREET WEST PALM BEACH, FL 33407. IT IS TO BE USED ONLY FOR THE PROJECT AND SHALL NOT BE REPRODUCED WITHOUT WRITTEN PERMISSION.

SCALE: 1=6

DATE: 6/19/13

CHECKED BY: