

PLAN

IMPORTANT INFORMATION

COMPLETE STEP BY STEP INSTALLATION INSTRUCTIONS ARE PROVIDED WITH EACH VALVE TO INSURE PROPER OPERATION. SEE BULLETIN# 6.3 READING THE ENTIRE PROCEDURE BEFORE ATTEMPTING INSTALLATION WILL SAVE TIME & MONEY.

1. OUTLET PIPE OF VALVE TO BE GROUTED IN PLACE BY CONTRACTOR.
2. LIFTING HARNESS IS SUPPLIED & INSTALLED FOR CONTRACTORS USE. MUST BE REMOVED AFTER INSTALLATION.
3. FLEXIBLE OUTLET CONNECTION SUPPLIED WITH EACH VALVE
4. 1"Ø VENT PIPE TO BE SUPPLIED & INSTALLED BY CONTRACTOR. VENT PIPE MUST BE EXTENDED ABOVE MAXIMUM OIL LEVEL OR OUTSIDE OF OIL SUMP. OIL MAY BYPASS STOP VALVE IF VENT IS NOT INSTALLED PROPERLY.
5. VALVE TO BE MOUNTED TO SUMP FLOOR. 1/2"Ø HOLES ARE PROVIDED IN BASE ANGLES.
6. VALVE VAULT MUST BE PRIMED WITH WATER & FLOAT OPENED PRIOR COMPLETION OF INSTALLATION.
7. MANUAL LIFTING CABLE HANDLE IS TO BE MOUNTED NEAR MANHOLE BY CONTRACTOR. DO NOT USE MANUAL LIFTING CABLE IF OIL IS PRESENT.

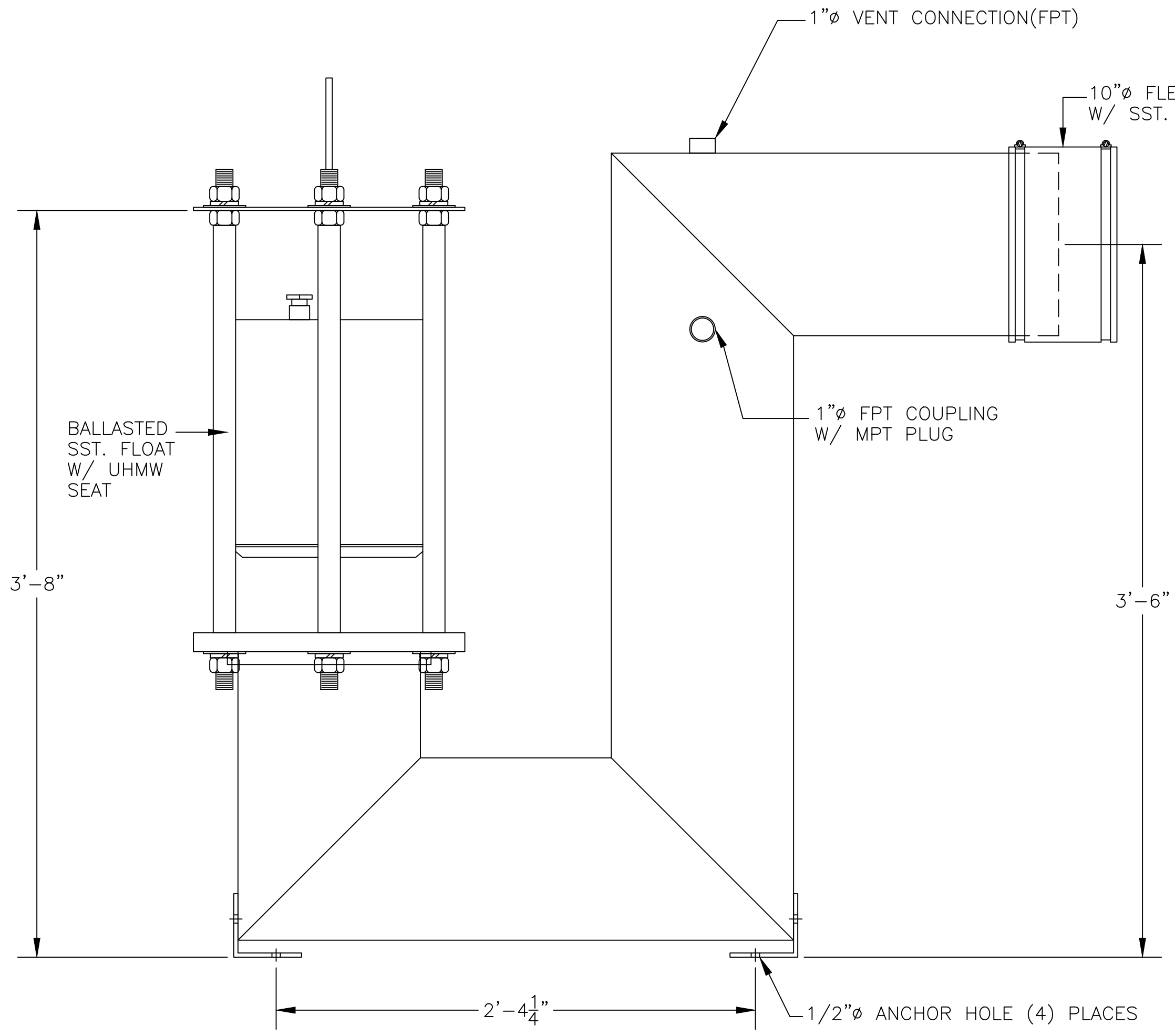

SIDE VIEW

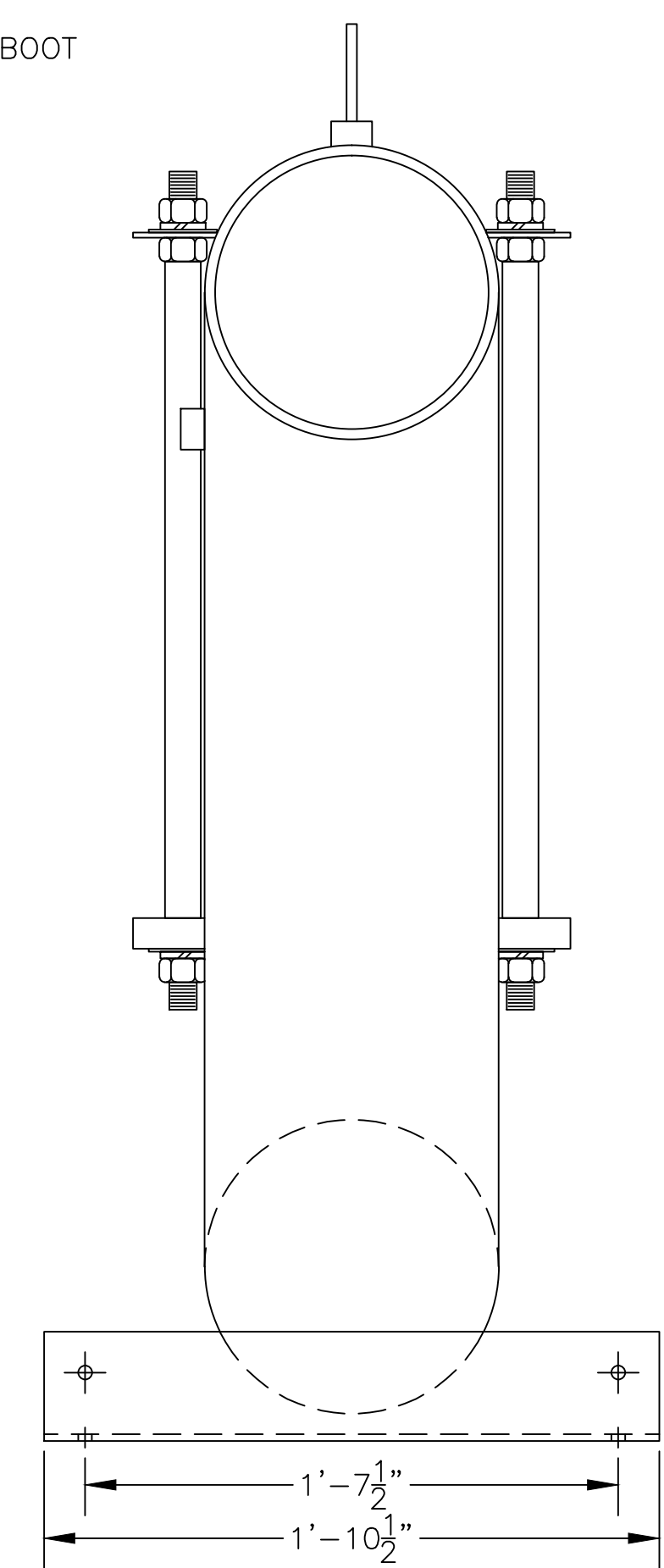

OUTLET END

| | | |
|--------------------------|--------------|-------------------|
| MODEL: OWS-OSV-10SST | OWS JOB No.: | - |
| | DRAWING No.: | 3S5020 |
| JOB: OWS TECHNOLOGIES | FILE: | OSV-10SST 6/19/13 |

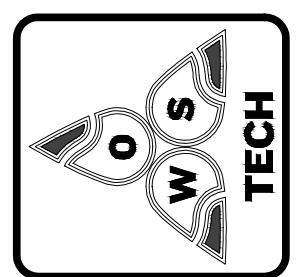

**OIL WATER SEPARATOR
TECHNOLOGIES, LLC**
1109 25TH STREET W.P.B., FL. 33407

| | |
|-------------|---------|
| SCALE: | 1 = 6 |
| DATE: | 6/19/13 |
| DRAWN BY: | TMB |
| CHECKED BY: | |

THIS DRAWING AND SPECIFICATION IS THE PROPERTY OF OWS TECHNOLOGIES 1109 25TH STREET WEST PALM BEACH, FL 33407. IT SHALL NOT BE REPRODUCED WITHOUT WRITTEN PERMISSION.