

### ASSEMBLY LIST

- ① 14"Ø INLET, FLANGED
- ② 14"Ø OUTLET, FLANGED
- ③ 4"Ø FPT DUPLEX SERVICE FITTING
- ④ 2'-6"Ø MANWAY W/ (2) FPT FITTINGS
- ⑤ COALESCING MEDIA
- ⑥ SLUDGE BAFFLE
- ⑦ 4"Ø FPT MONITOR FITTING OR OPTIONAL HYDROSTATIC RESERVOIR (DW ONLY)
- ⑧ LIFTING LUGS
- ⑨ OPTIONAL PREFABRICATED DEADMAN

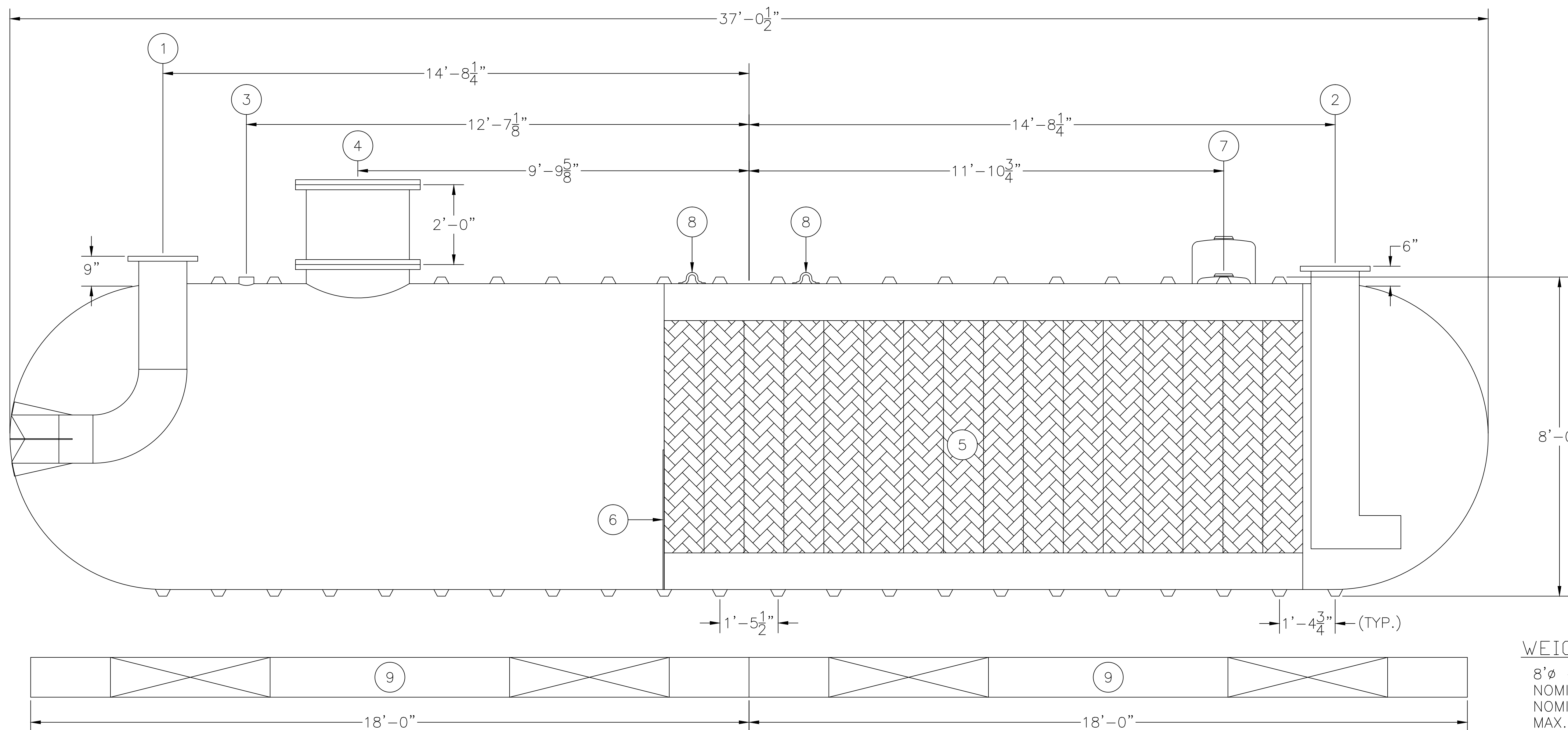

### WEIGHTS & CAPACITIES

8'Ø - 12,000 GAL. TANK SW OR DW  
 NOMINAL WGT. SW 7,400#  
 NOMINAL WGT. DW 9,200#  
 MAX. SPILL CAPACITY 7,200 GAL.

**OIL WATER SEPARATOR**  
**TECHNOLOGIES LLC**  
 1109 25TH STREET W.P.B., FL. 33407

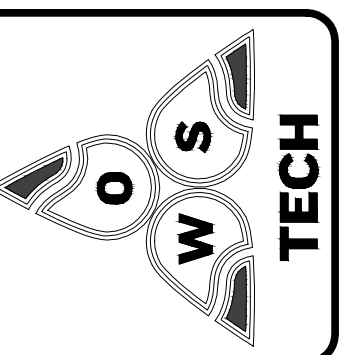

OWS JOB No. -

MODEL: HB-F-8-12K-16 1,216 G.P.M.

DRAWING No. 4S5079  
 FILE: 8-12K-1216-SWDW 12/19/14

JOB: OWS TECHNOLOGIES

SCALE: N.T.S.

DATE: 12/19/14

THIS DRAWING AND SPECIFICATION IS THE PROPERTY OF OWS TECHNOLOGIES 1109 25TH STREET WEST PALM BEACH, FL. 33407 AND SHALL NOT BE REPRODUCED WITHOUT WRITTEN PERMISSION.

DRAWN BY: TMB

CHECKED BY: