

ASSEMBLY LIST

- ① 8"Ø INLET, FLANGED
- ② 8"Ø OUTLET, FLANGED
- ③ 4"Ø FPT DUPLEX SERVICE FITTING
- ④ 2'-6"Ø MANWAY W/ (2) FPT FITTINGS
- ⑤ COALESCING MEDIA
- ⑥ SLUDGE BAFFLE
- ⑦ 4"Ø FPT MONITOR FITTING OR OPTIONAL HYDROSTATIC RESERVOIR (DW ONLY)
- ⑧ LIFTING LUGS
- ⑨ OPTIONAL PREFABRICATED DEADMAN

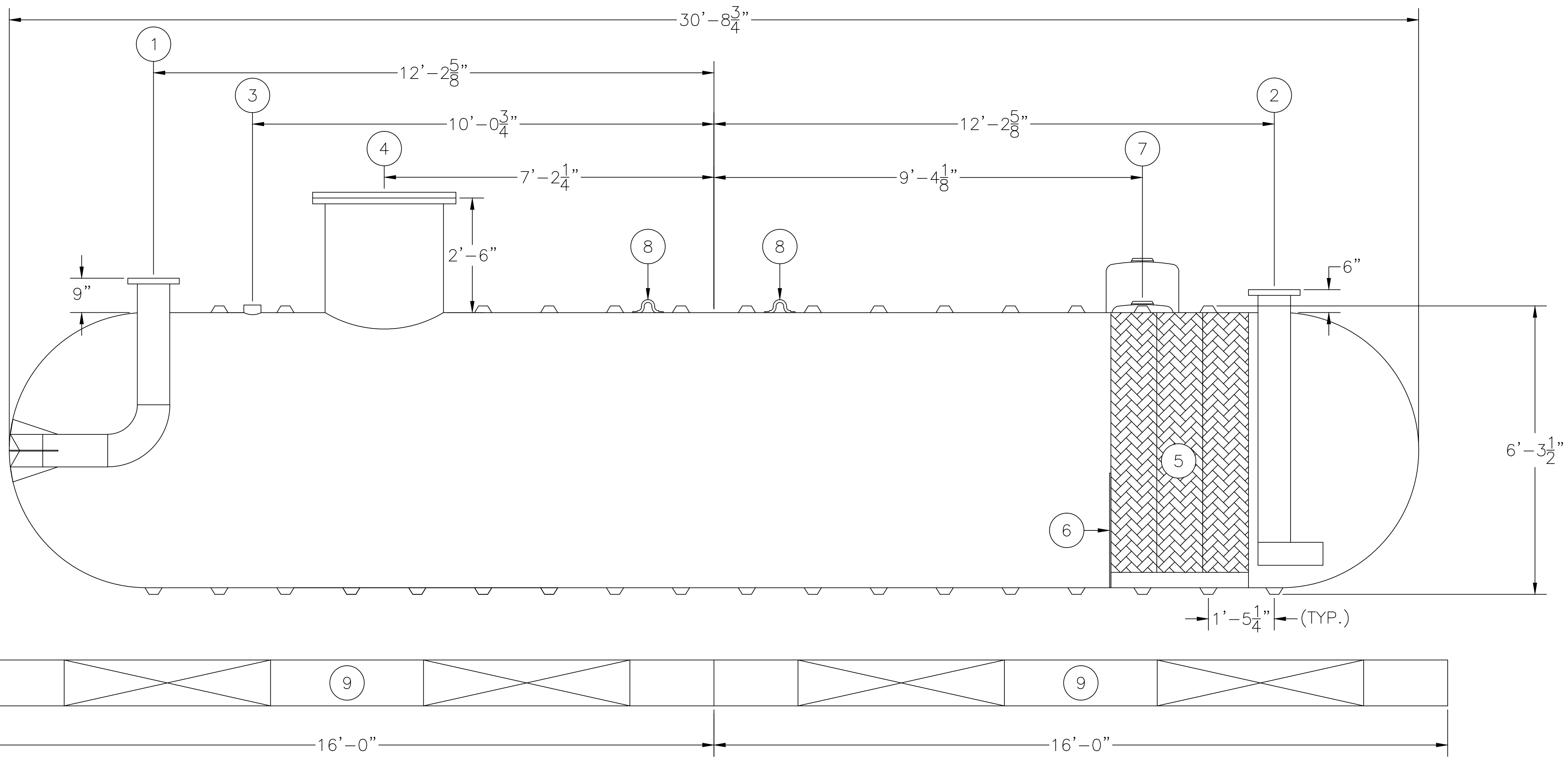

WEIGHTS & CAPACITIES

6'Ø - 6,000 GAL. TANK SW OR DW
 NOMINAL WGT. SW 5,100#
 NOMINAL WGT. DW 6,000#
 MAX. SPILL CAPACITY 3,600 GAL.

MODEL: HB-F-6-6K-3 219 G.P.M.	OWS JOB No. -	OIL WATER SEPARATOR TECHNOLOGIES LLC 1109 25TH STREET W.P.B., FL. 33407	DRAWN BY: TMB CHECKED BY:
JOB: OWS TECHNOLOGIES	DRAWING No. 4S5051 FILE: 6-6K-219-SWOW 12/18/14		THIS DRAWING AND SPECIFICATION IS THE PROPERTY OF OWS TECHNOLOGIES, 1109 25TH STREET WEST PALM BEACH, FL. 33407 AND SHALL NOT BE REPRODUCED WITHOUT WRITTEN PERMISSION.
SCALE: N.T.S.	DATE: 12/18/14		