

HOLD DOWN STRAP LOCATION

HOLD DOWN STRAP LOCATION

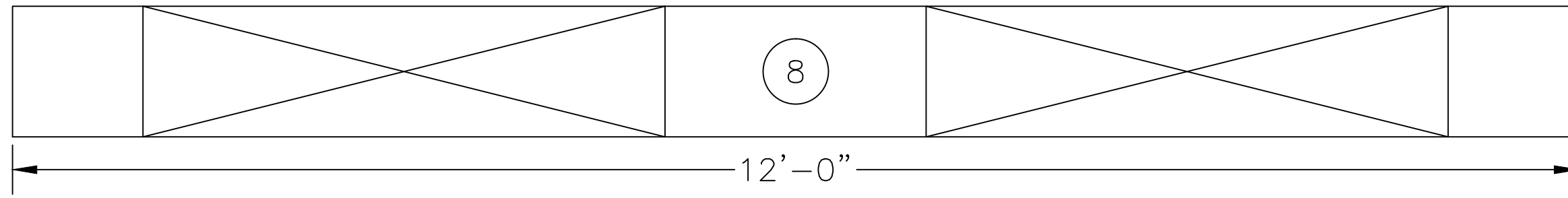
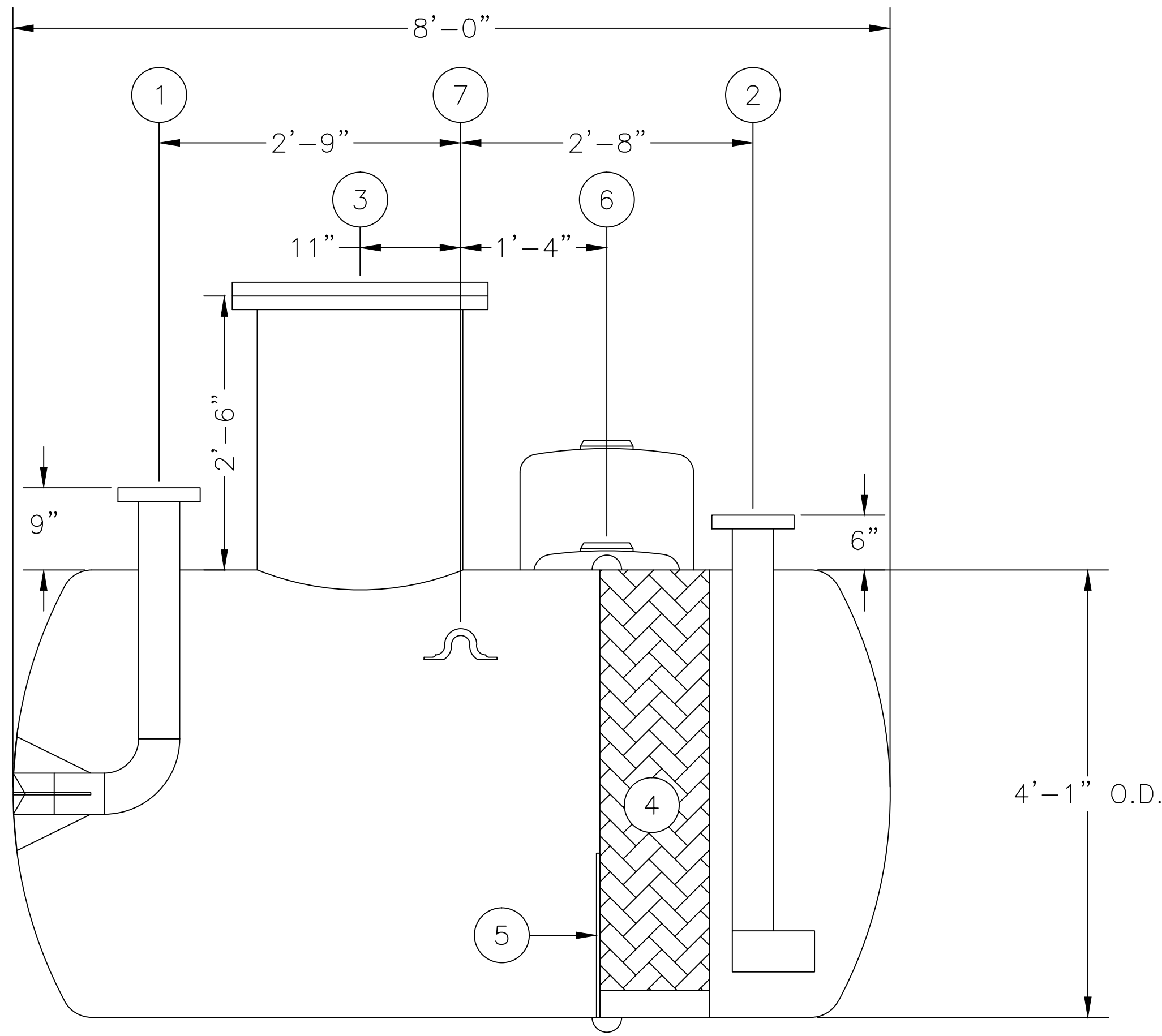
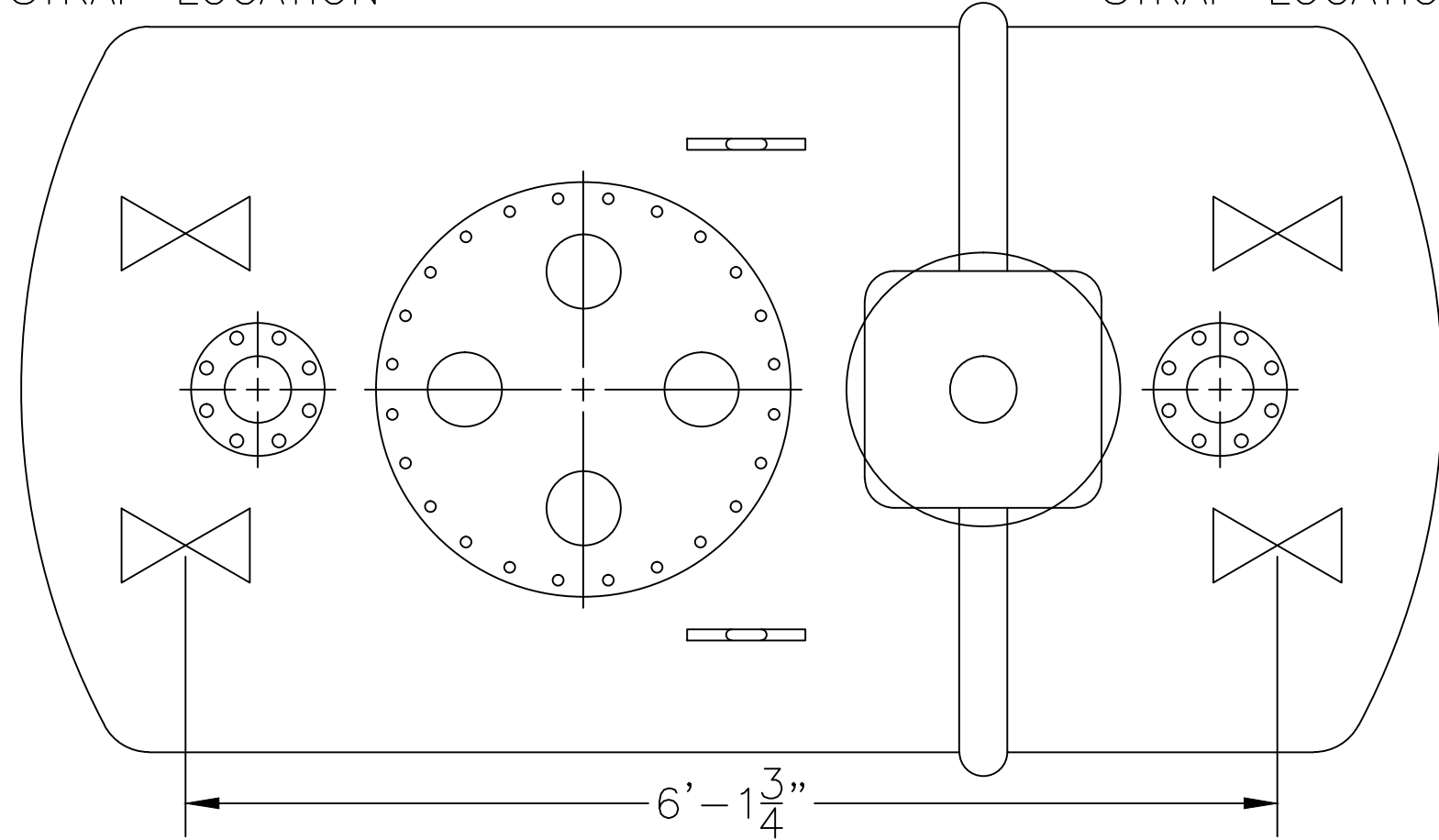

**ASSEMBLY LIST**

- ① 4"Ø INLET, FLANGED
- ② 4"Ø OUTLET, FLANGED
- ③ 1'-10"Ø MANWAY W/ (4) FPT FITTINGS
- ④ COALESCING MEDIA
- ⑤ SLUDGE BAFFLE
- ⑥ 4"Ø FPT MONITOR FITTING OR OPTIONAL HYDROSTATIC RESERVOIR
- ⑦ LIFTING LUG
- ⑧ OPTIONAL PREFABRICATED DEADMAN

**WEIGHTS & CAPACITIES**

4'Ø - 700 GAL. TANK DW  
 NOMINAL WGT. 1,000#  
 MAX. SPILL CAPACITY 400 GAL.

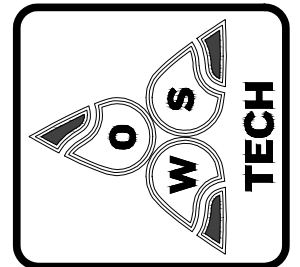

**OIL WATER SEPARATOR**  
**TECHNOLOGIES, LLC**  
 1109 25TH STREET W.P.B., FL. 33407

OWS JOB No. -

MODEL: HB-F-4-700-1 DW 34 G.P.M.

DRAWING No. 3S5065  
 FILE: 4-700-34-DW 12/12/13

JOB: OWS TECHNOLOGIES

SCALE: N.T.S.

THIS DRAWING AND SPECIFICATION IS THE PROPERTY OF OWS TECHNOLOGIES 1109 25TH STREET WEST PALM BEACH, FL 33407. IT SHALL NOT BE REPRODUCED WITHOUT WRITTEN PERMISSION.

DATE: 12/12/13

DRAWN BY: TMB

CHECKED BY: