

HOLD DOWN STRAP LOCATION

HOLD DOWN STRAP LOCATION

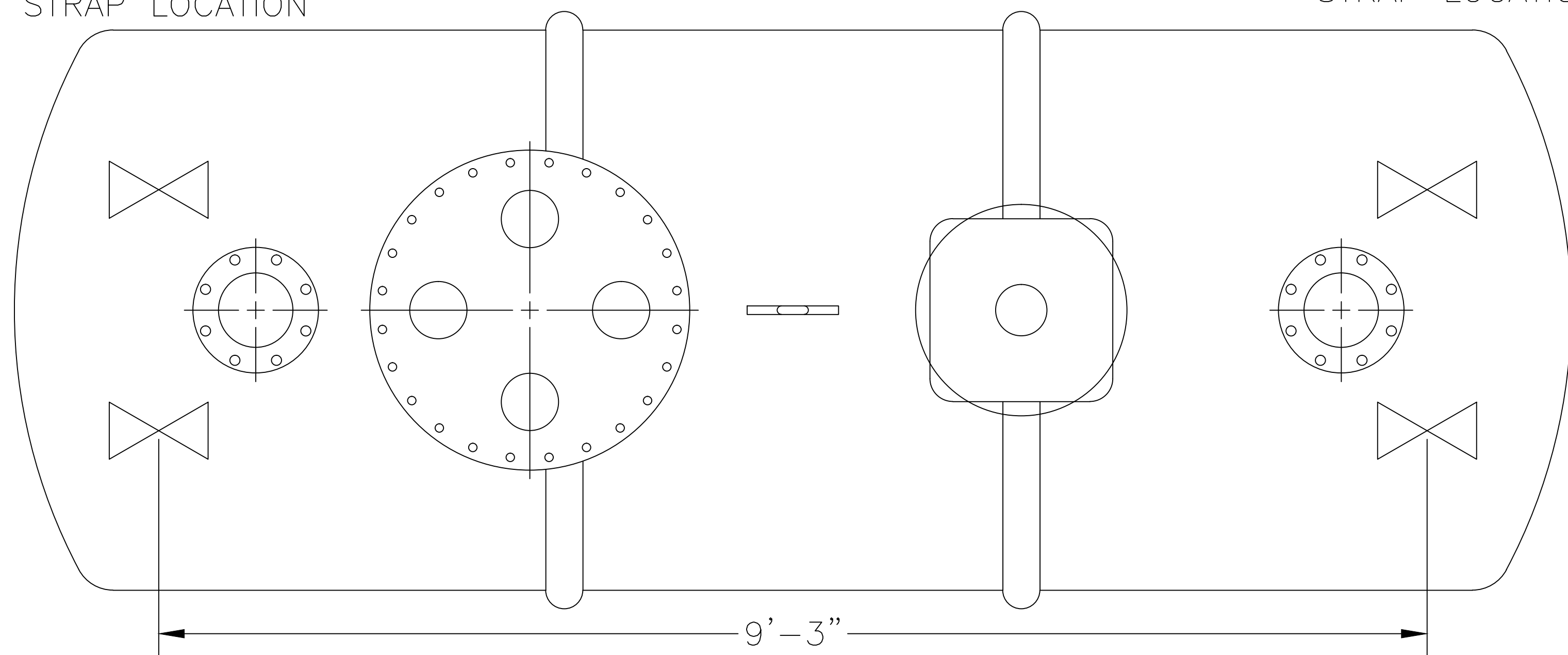

ASSEMBLY LIST

- ① 6"Ø INLET, FLANGED
- ② 6"Ø OUTLET, FLANGED
- ③ 1'-10"Ø MANWAY W/ (4) FPT FITTINGS
- ④ COALESCING MEDIA
- ⑤ SLUDGE BAFFLE
- ⑥ 4"Ø FPT MONITOR FITTING OR OPTIONAL HYDROSTATIC RESERVOIR (DW ONLY)
- ⑦ LIFTING LUG
- ⑧ OPTIONAL PREFABRICATED DEADMAN

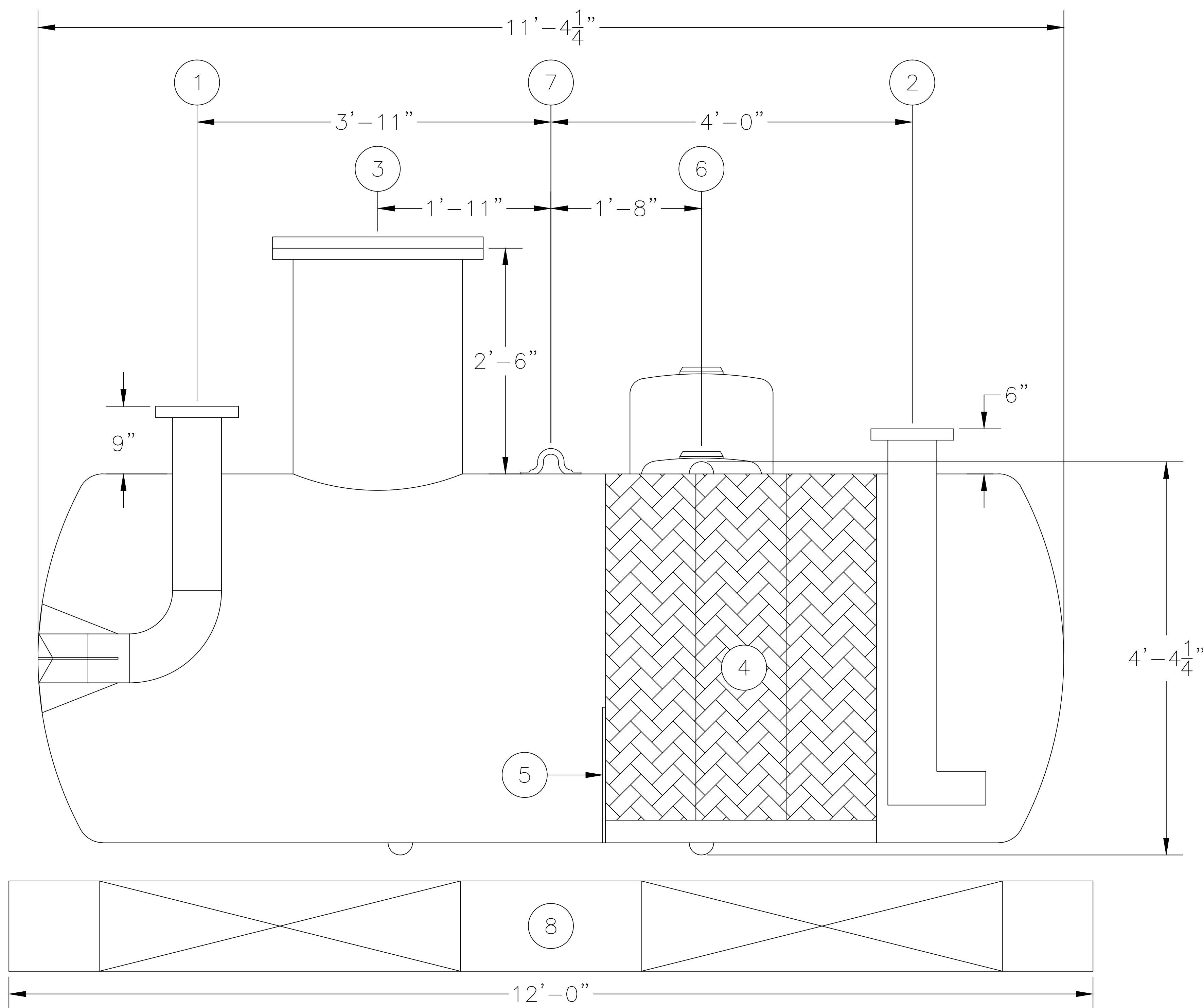

WEIGHTS & CAPACITIES

4'Ø - 1,000 GAL. TANK SW OR DW
 NOMINAL WGT. SW 1,400#
 NOMINAL WGT. DW 1,700#
 NOMINAL OIL STORAGE 100 GAL.
 MAX. SPILL CAPACITY 600 GAL.

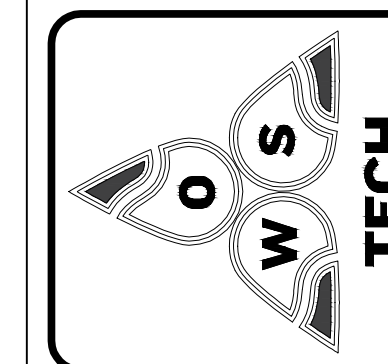

OIL WATER SEPARATOR
TECHNOLOGIES, LLC
 1109 25TH STREET W.P.B., FL. 33407

DRAWN BY: TMB

CHECKED BY:

THIS DRAWING AND SPECIFICATION IS THE PROPERTY OF OWS TECHNOLOGIES 1109 25TH STREET WEST PALM BEACH, FL. 33407 AND SHALL NOT BE REPRODUCED WITHOUT WRITTEN PERMISSION.

SCALE: N.T.S.

DATE: 3/17/14

OWS JOB No. -

MODEL: HB-F-4-1K-3 102 G.P.M.

DRAWING No. 3S5073
 FILE: 4-1K-102-SWDW 3/17/14

JOB: OWS TECHNOLOGIES