

IT Startup/Creative Economy

Manoo Ordeedolchest

Honorary President

The Association of Thai ICT Industry

Unlocking ICT—an enabler for innovative growth

July 2, 2013

Central Grand at Central World

Old Business Model Is Not Fit For Today

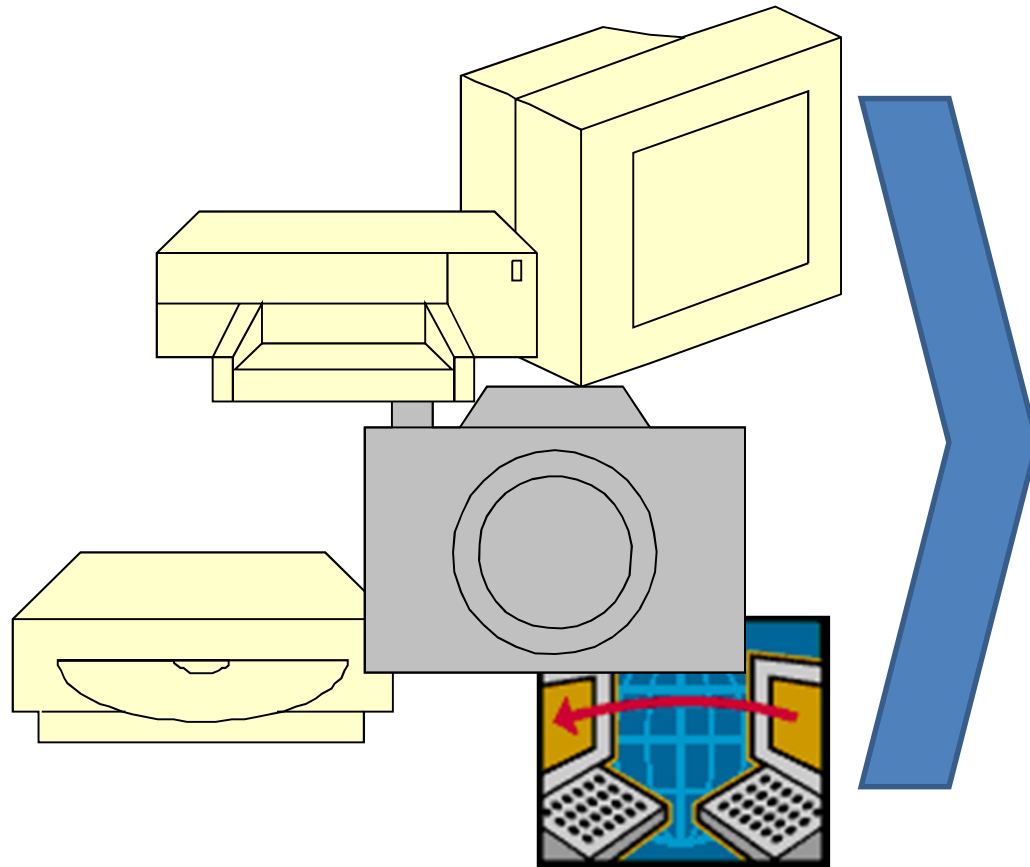

Commoditizing
No More!

People do not want
computers and software—
they need solutions

“Offering” for Value Creation

Collaborative
Competency



Suppliers
Service Providers

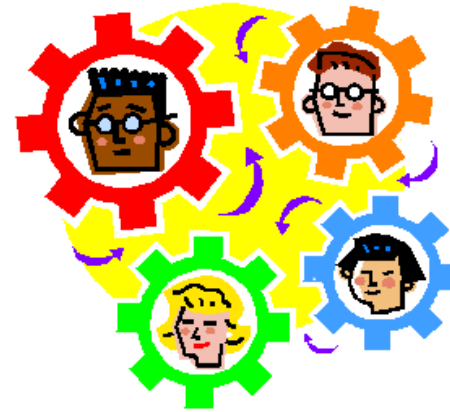

Customers
Value co-creation



The Connected World



Broadband Internet

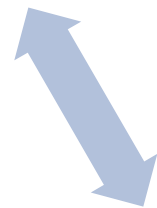
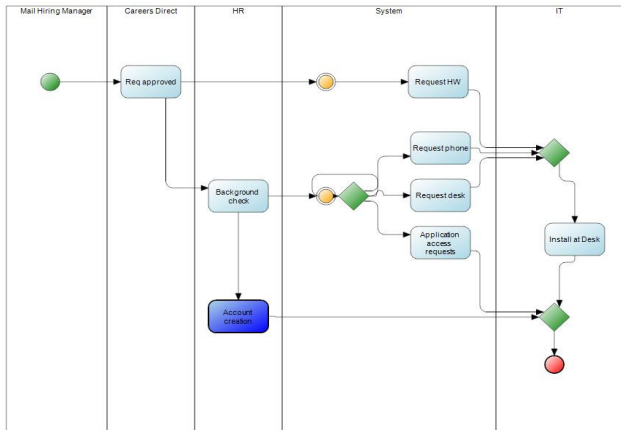

Connecting resources and capability



Connecting end customers

Value Constellation:

a web of activities and actors that create “Offerings”

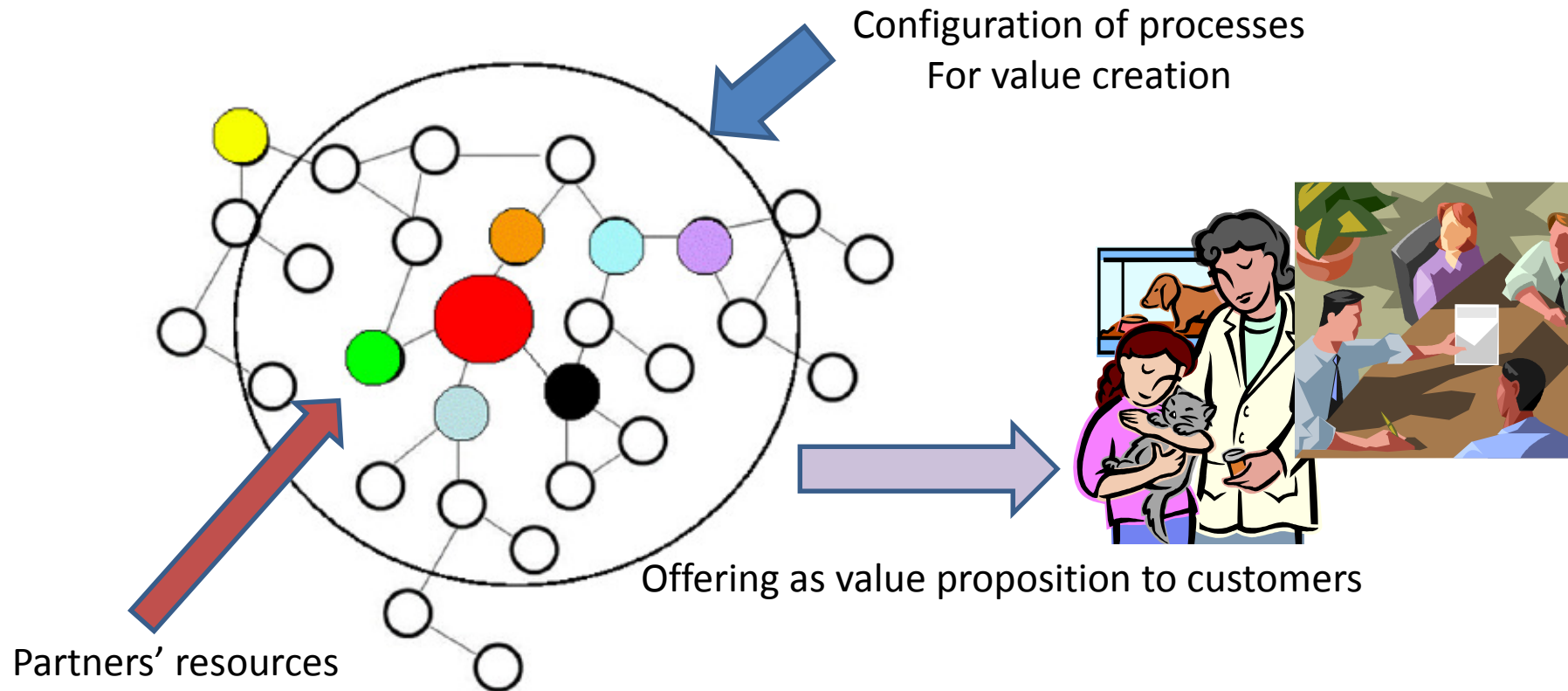

The Value Creation System

source: www.synocus.com

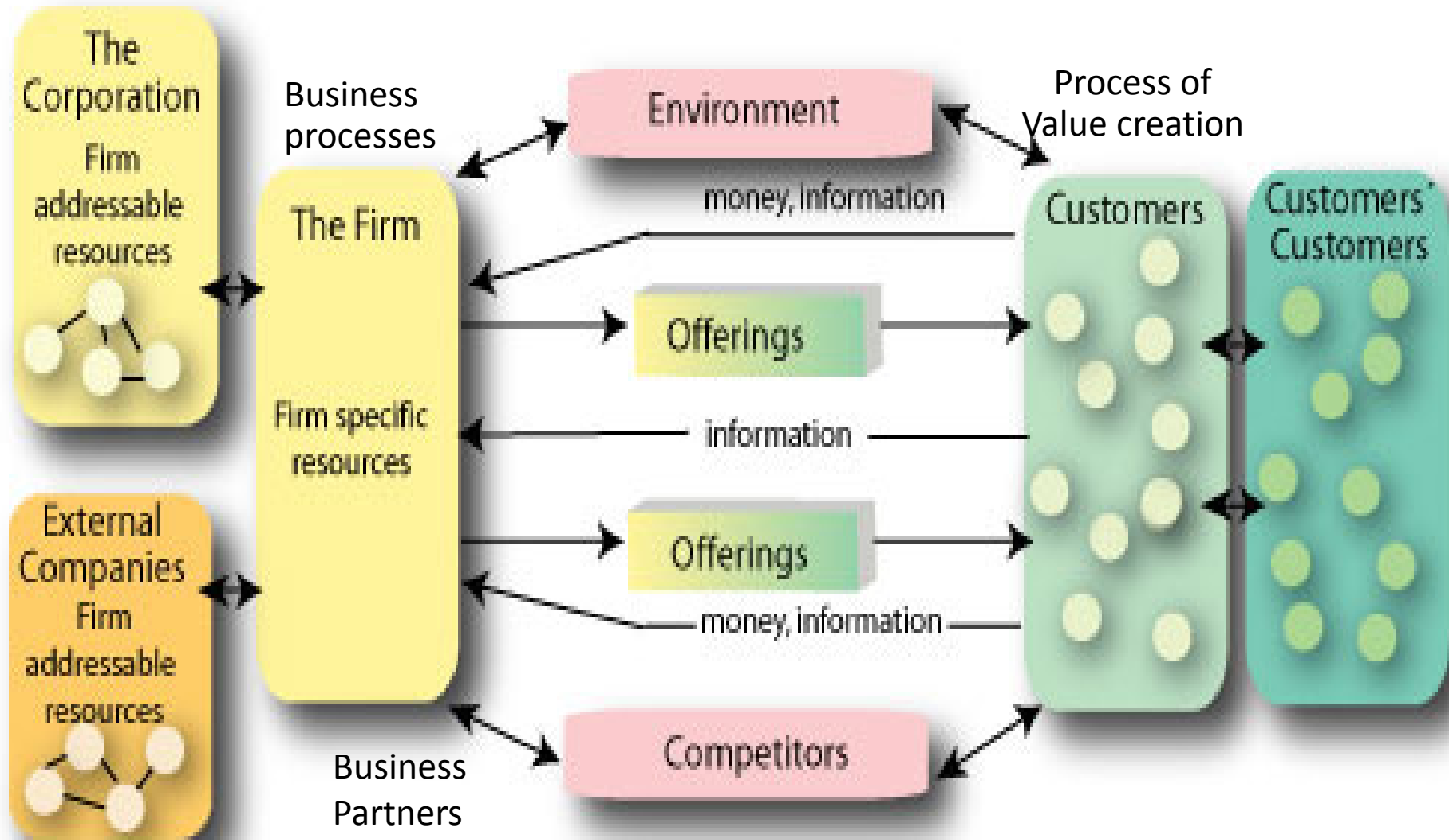

The New Business Model

Value chain

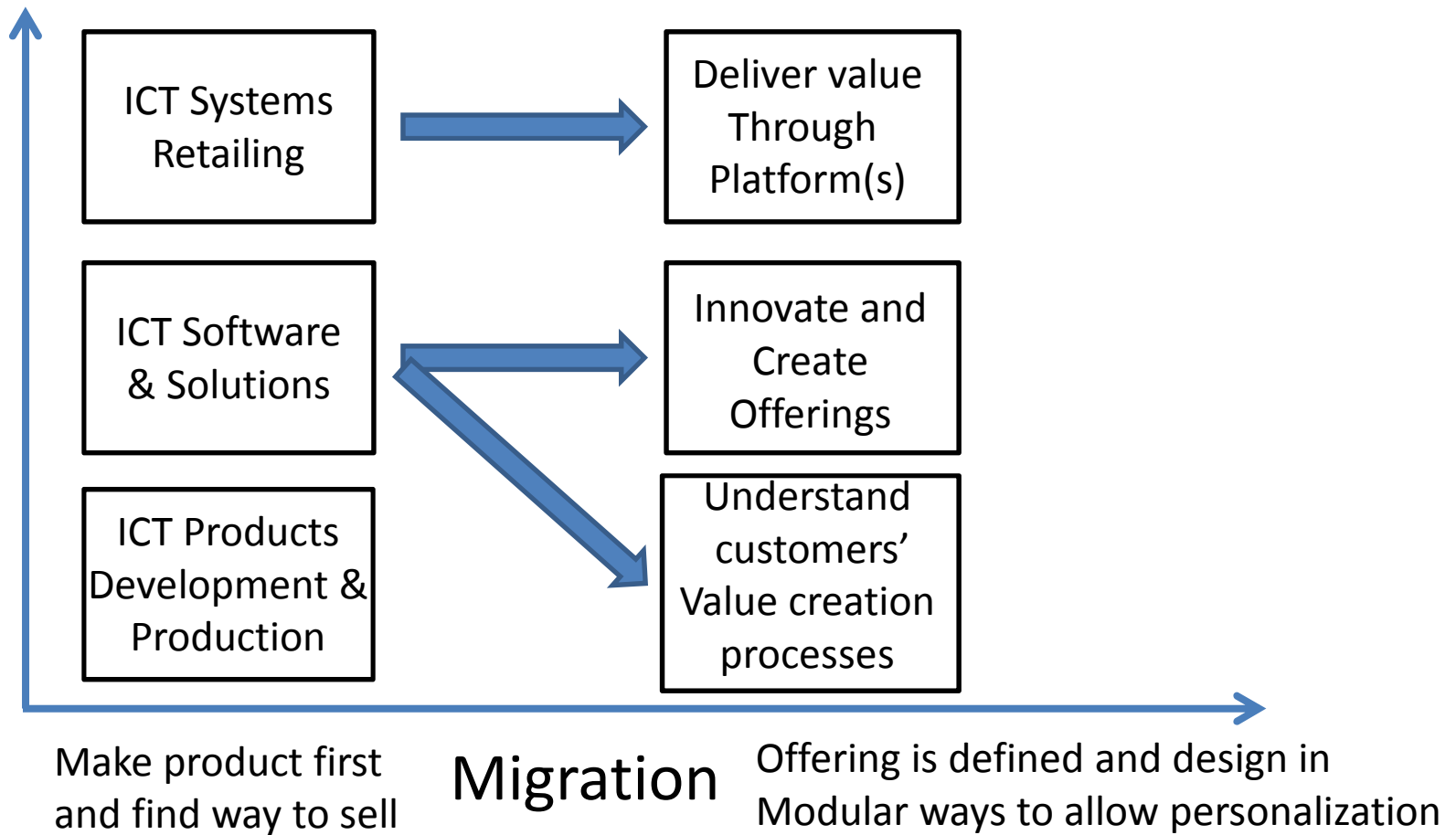

Thank You