

Form 3: Conveyance Allowance application - Public transport travel only

Year		Term		PLEASE ENSURE ALL PAGES ARE COMPLETED AND SIGNED				
<p>If there are more than three students claiming from this home residence, please complete another Form 3 and attach together. <i>Note:</i> An eligible student may be granted an allowance based on the least expensive public transport fares only. A copy of your ticket/fare purchase should be attached to this form e.g. Victorian Student Pass, Transit Student Pass.</p> <p>Please complete Form 5 for Multi-mode conveyance allowance: when a student uses more than one mode of transport (e.g. private car and public transport) for a journey between home and school. The distance travelled must be 4.8km or more for each leg of the journey.</p>								
APPLICANT DETAILS								
RESIDENTIAL STREET ADDRESS								
Unit #		Street #		Address				
Town/Suburb					State		Postcode	
Exact distance (in km) from home to school by the shortest practicable route						km		
PARENT/GUARDIAN DETAILS								
First Name				Surname		Telephone		
First Name				Surname		Telephone		
Email								
TRAVELLER DETAILS								
Student one								
First Name		Surname		Date of birth		Travel start date		
School enrolled				Year level				
VSN				FTE (student must attend 3 days i.e. FTE 0.6 or more):				
Student claiming (please use X to highlight)								
To/from school				<input type="checkbox"/>	To/From School and off campus			
Student two								
First Name		Surname		Date of birth		Travel start date		
School enrolled				Year level				
VSN				FTE (student must attend 3 days i.e. FTE 0.6 or more):				
Student claiming (please use X to highlight)								
To/from school				<input type="checkbox"/>	To/From School and off campus			
Student three								
First Name		Surname		Date of birth		Travel start date		
School enrolled				Year level				
VSN				FTE (student must attend 3 days i.e. FTE 0.6 or more):				
Student claiming (please use X to highlight)								
To/from school				<input type="checkbox"/>	To/From School and off campus			

Eligibility

An application on behalf of a student may be submitted if the student is:

- a Victorian resident.
- school aged and enrolled (3) three or more days per week at a school; and
- attending a school/campus located outside the Melbourne metropolitan conveyance boundary

A student who meets the above requirements may be eligible if they:

- attend their nearest or designated neighbourhood government school/campus appropriate to their year level, at which admission is permissible, or
- attend their nearest appropriate non-government school/campus appropriate to their year level, at which admission is permissible, and
- reside 4.8km or more by the shortest practicable route from the campus attended

Note: Eligibility is assessed when the School completes your child's application on the Student Conveyance Allowance System (SCAS). If approved, the allowance payable is based on the one-way distance to make the journey to and from school. For further information regarding the Conveyance Allowance Program see: <https://www2.education.vic.gov.au/pal/conveyance-allowance/policy?Redirect=1>

***Multi-mode conveyance allowances**

Multi-mode conveyance allowance applies when a student uses more than one mode of transport (e.g. private car and public transport) for a journey between home and school.

Refer to Form 5.

OFFICE USE ONLY							
Date Form Submitted		Form Signed - Yes/No – if no, return to Parent/Guardian for signature					
Copy of ticket/fare purchase attached?		Proof of fare/ticket - Yes/No – if no, return to Parent/Guardian for copy to attach					
Parent/Guardian signed?		Date entered/assessed on SCAS		Eligible on SCAS - Y/N?			
Ticket Frequency (circle):	Daily	Weekly	Fortnightly	Monthly	Term	Half Yearly	Yearly
Ticket Amount:							
Service Operator (if known)							
Service Route (if known):							
<p>Have any of these students been granted eligibility on the basis of an exemption? If yes, specify exemption from policy e.g. lack of available spaces at nearest school/s, Special Case Panel Approval. Attach proof for this application e.g. Letter(s) confirming refused entry from all nearer schools. The letter(s) should be dated prior to the commencement date of the student at the school applying for the conveyance allowance.</p>							
Student one							
Student two							
Student three							
<p>Note: Students not attending their nearest school/campus may qualify for a conveyance allowance in some circumstances only. Sibling rights do not apply in any of these circumstances. Further information regarding these circumstances can be found in the Conveyance Allowance Program policy available online at: https://www2.education.vic.gov.au/pal/conveyance-allowance/guidance or by contacting your school.</p>							

OFFICE USE ONLY

School SCAS Coordinator Name (please print): _____

School Signature – Principal / Delegate signature: _____

Date _____

PARENT/GUARDIAN TO COMPLETE:

I certify that:

1. All the above details are true and correct to my knowledge.
2. I will notify the principal/delegate in writing within 7 days of any change of address or school.
3. The school will use personal information I have provided such as my address, child's enrolment details to assess and confirm their eligibility for the Conveyance Allowance Program using the Student Conveyance Allowance System (SCAS).
4. I consent to release this information to Department of Education (DET) representatives to assist with assessing my application on SCAS.
5. I understand the conveyance allowance is for the student/s named on the application form/s and cannot be withheld by the school in lieu of fees or late payments.
6. I understand my signed consent is required with this application form for the school to keep the conveyance allowance as a contribution towards school purchased tickets/fares to and from school only (*if you agree to give consent, please complete/sign consent below*).

Parent/guardian name (please print) _____

Parent/guardian signature _____

Date _____

PARENT/GUARDIAN CONSENT FOR SCHOOL TO WITHHOLD CONVEYANCE ALLOWANCE:

I consent that:

1. The conveyance allowance payable to the student/s named on this application form will be withheld by the school as a contribution towards school purchased tickets/fares to and from school only.
2. I understand there may be additional costs incurred which the school may request that I cover.
3. I understand the conveyance allowance cannot be withheld or contribute towards procured bus services for school excursions.
4. I will notify the principal/delegate in writing if I wish to withdraw my consent to withhold my child's conveyance payments.
5. I understand withdrawal of my consent may not be effective until the next term claim period.

Parent/guardian name (please print) _____

Parent/guardian signature _____

Date _____

2022 PTV School Student ID and Student Pass application form*

Applicant details

First name

Last name

Address (please leave a gap between numbers and words)

State

Postcode

Phone number

School declaration

I confirm the details of the student named in this application form are correct. I've checked the student's school records and the student is full-time and eligible for a PTV School Student ID. I agree that this school will let PTV know if these details change.

Signature of Principal, Bursar, Registrar or Secretary

Date

Name of signatory

School Name

School telephone number

Official school stamp

*A \$9 application fee applies.

Please attach photos here

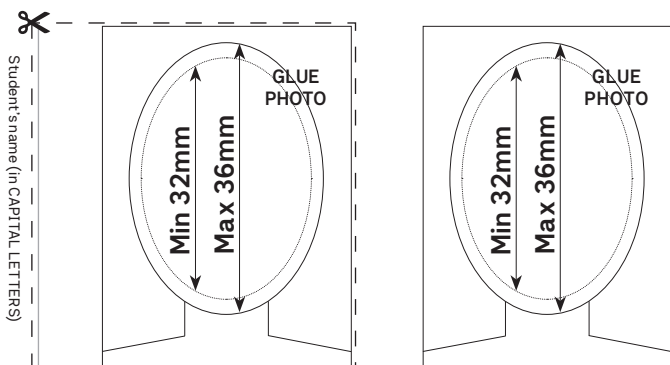

- Photos must be passport style and include head and shoulders. School photos or photos taken using a smartphone against a white background may be used
- Make sure they're colour, in focus and identical
- Don't use sticky tape
- Stamp the photos with your official stamp. Stamp the top left hand corner, not over the face.

Locations of issue: Metropolitan Premium Stations, staffed V/Line Stations, PTV Hubs, regional bus operators & V/Line ticket agents. Call 1800 800 007 for locations and hours of operation or visit ptv.vic.gov.au

Some stations may not be able to process forms before 9.30am and between 3.30pm to 6.00pm on weekdays.

