



WARNING

MAKE SURE THE POWER IS TURNED OFF AND PROPER LOCK AND TAG PROCEDURE HAS BEEN FOLLOWED

- Remove accessories installed on end flange (transmitters, valves, & sensors)
- Remove the downstream cover
- Remove the seal retainer
- Remove the DOWN STREAM end flange bracket and the end flange
- Disconnect upstream shaft from shuttle
- Remove the piston assembly
- Remove the piston support from the piston body and remove the seals
- For installation, reverse the process and follow from step six back to step one
- Please refer to torque table for all relevant hardware replacement

Note:

- a. ANTI-SEIZE lubricant must be applied to following bolts:
 - i. Seal retainer bolts
 - ii. End flange bolts



DO NOT APPLY LOCTITE TO BOLTS IN NOTE “a”

- b. All hardware must be torque per ASTM 307
- c. Apply LOCKTITE 242 to all standard hardware **(Except bolts in note “a”)**

Figure 1 - Top View - Full Assembly

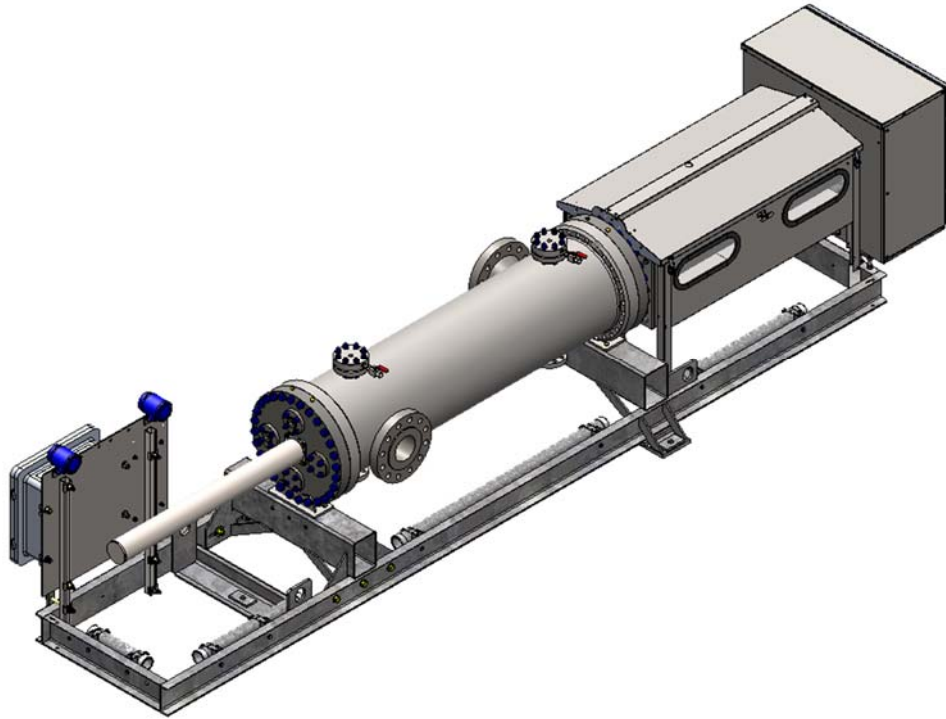

Figure 2 - Move piston upstream

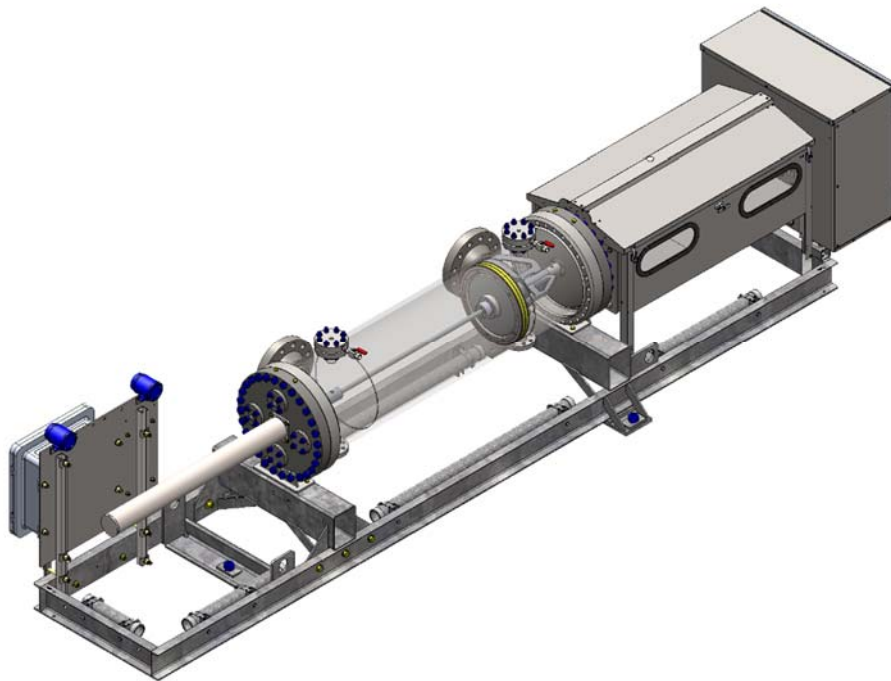

Figure 3 - Remove downstream components

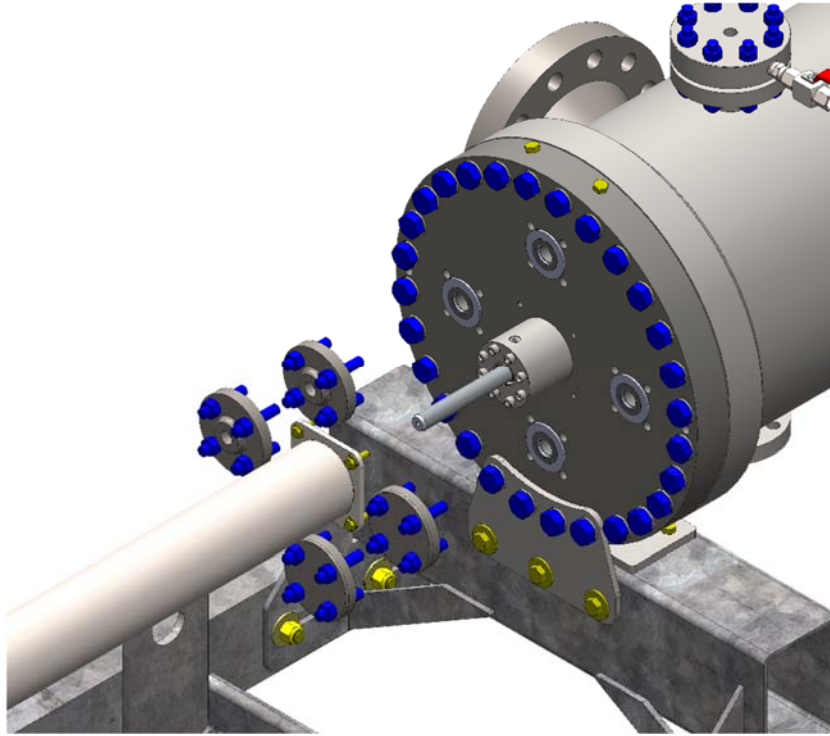

Figure 4 - Remove seal retainer

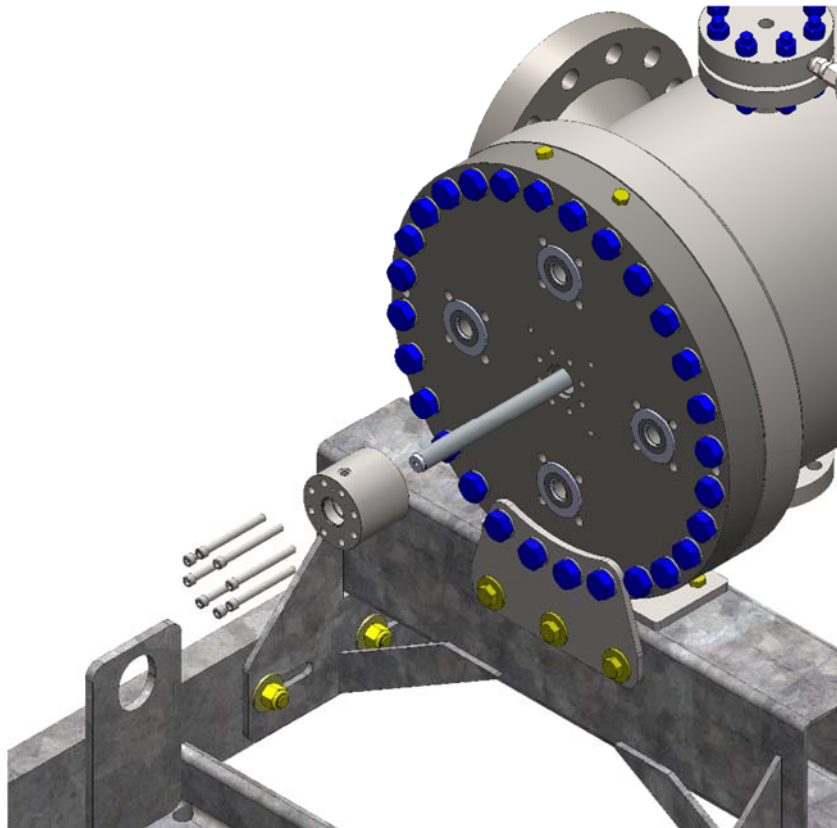

Figure 5 - Remove flange and bracket hardware

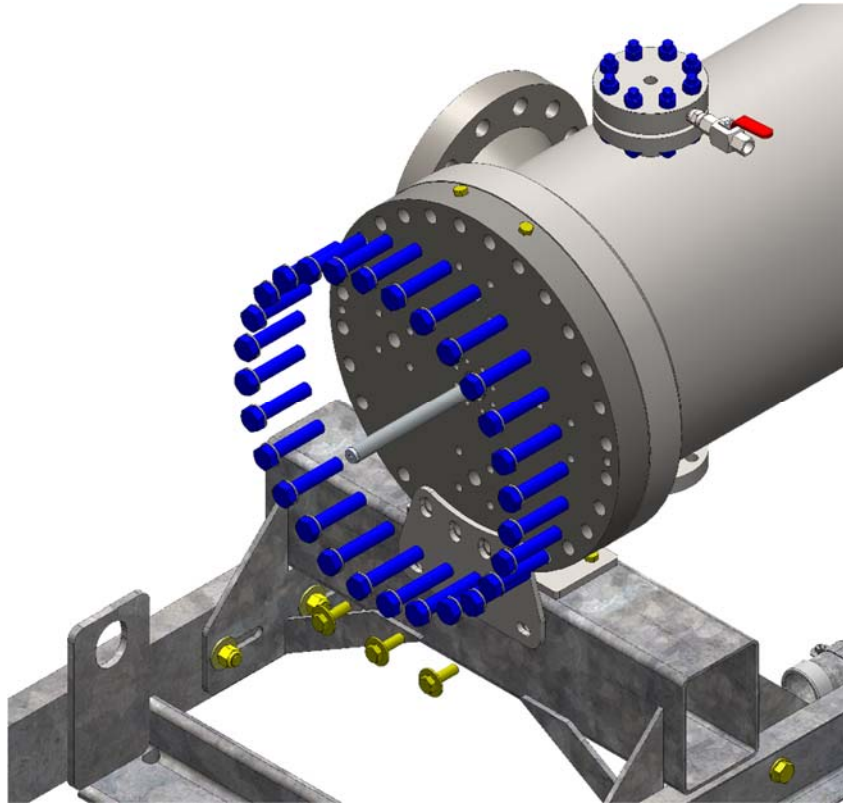

Figure 6 - Remove end flange

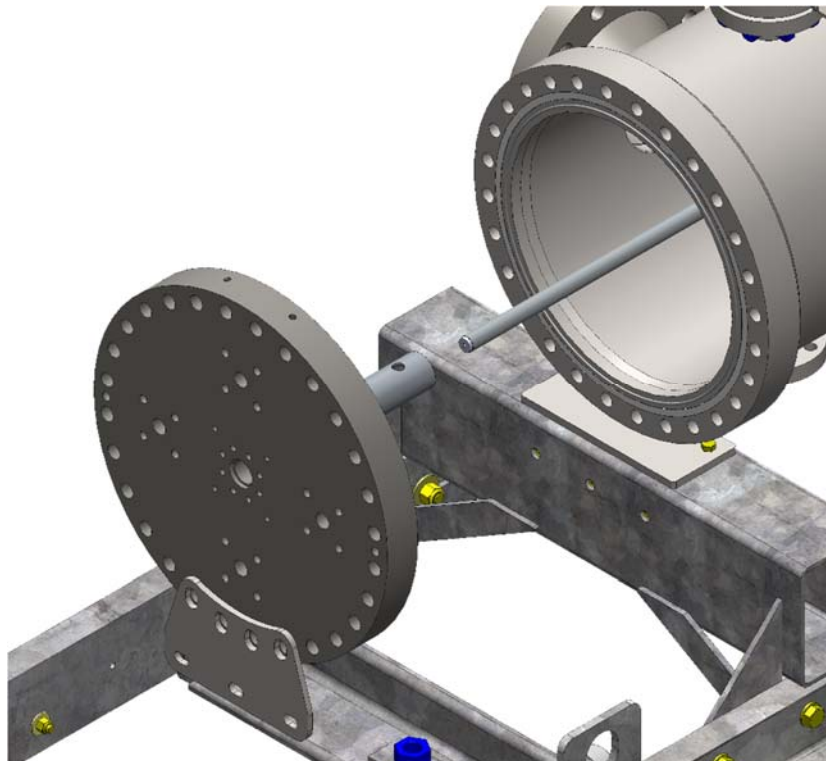

Figure 7 – Disconnect upstream shaft from shuttle

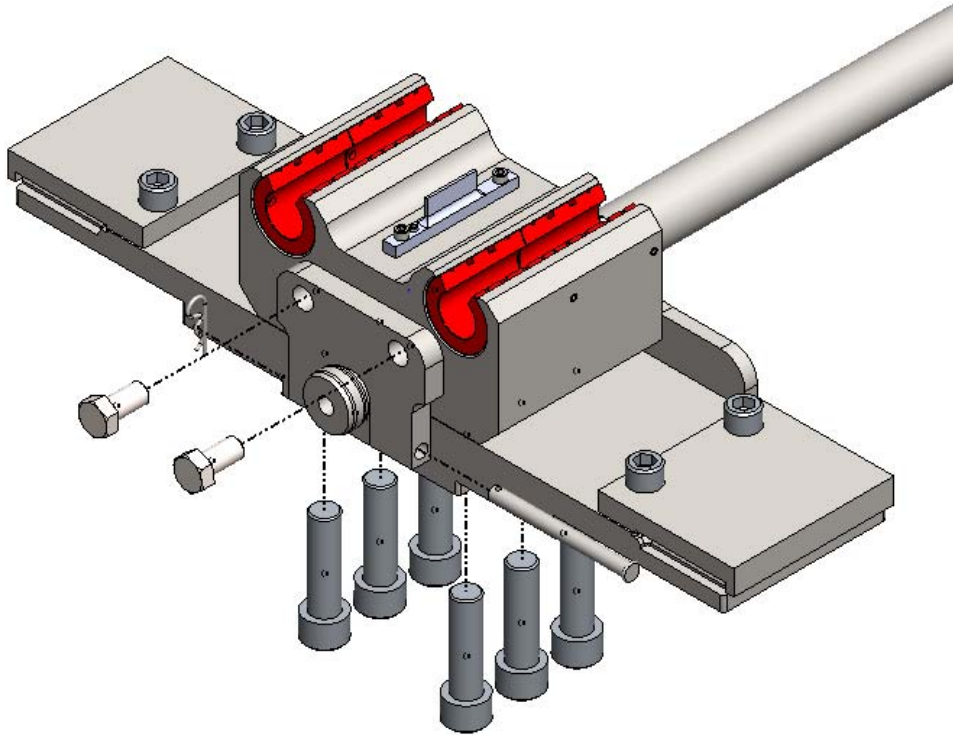

Figure 8 - Pull out shaft and poppet assembly

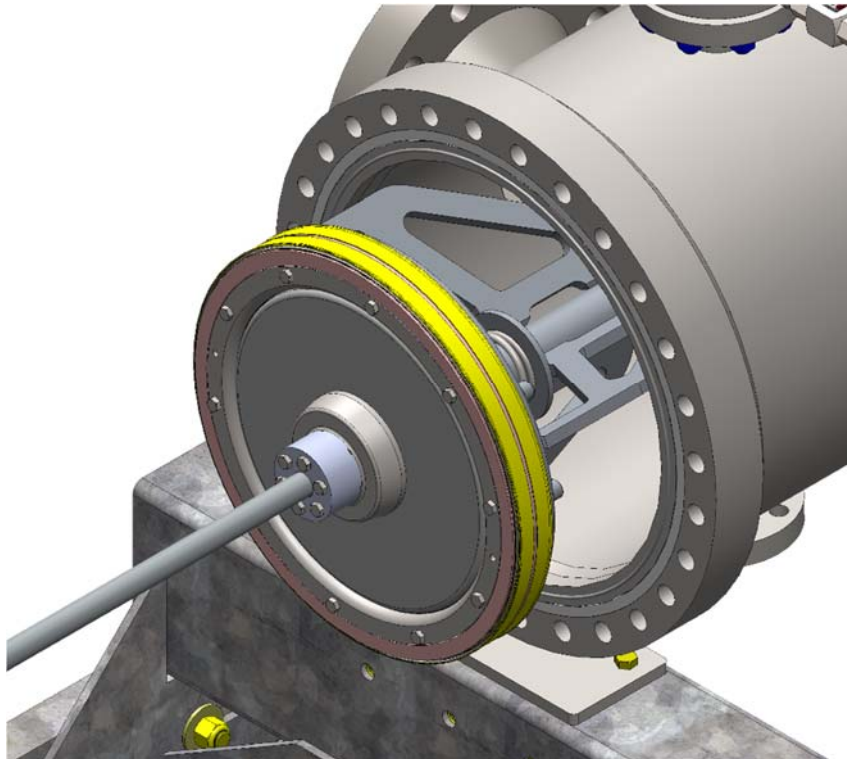

Figure 9 - Remove seal retention ring

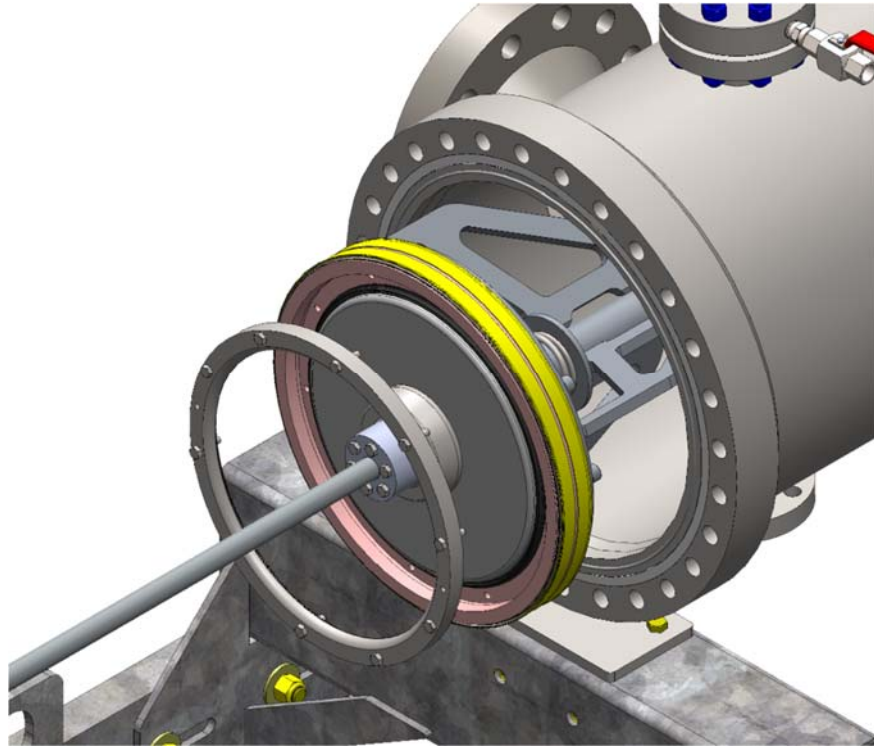

Figure 10 - Remove seals

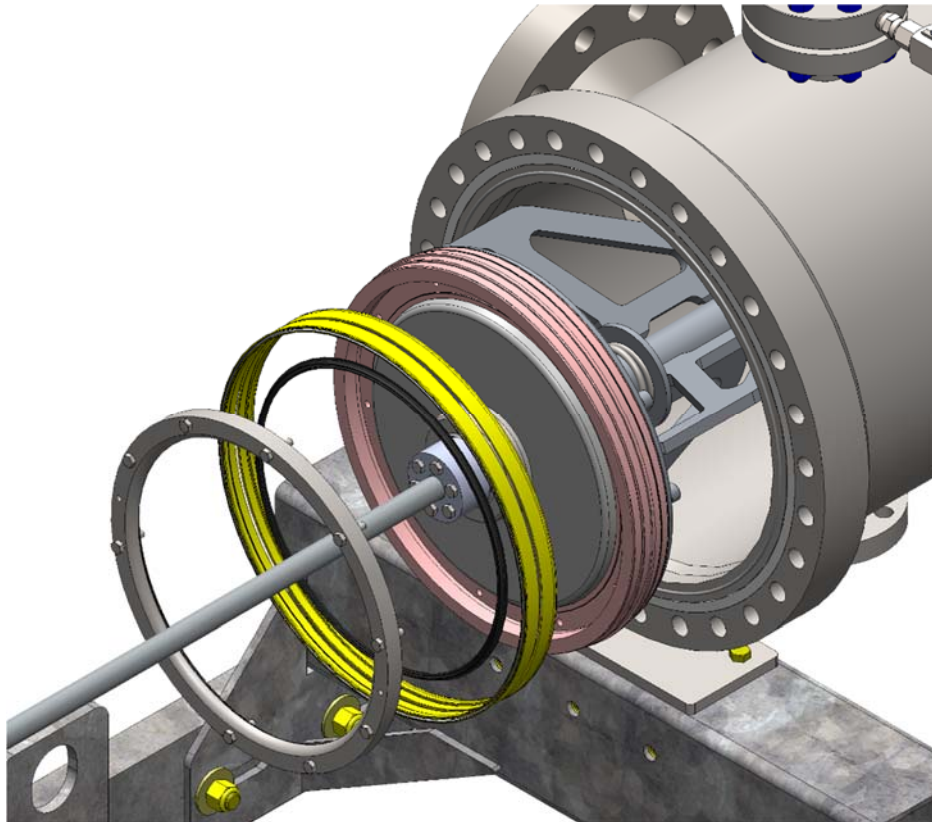

Figure 11 - Remove shaft poppet assembly



Figure 12 - Remove Seals



Figure 13 - Seals

