

# MOUNTING

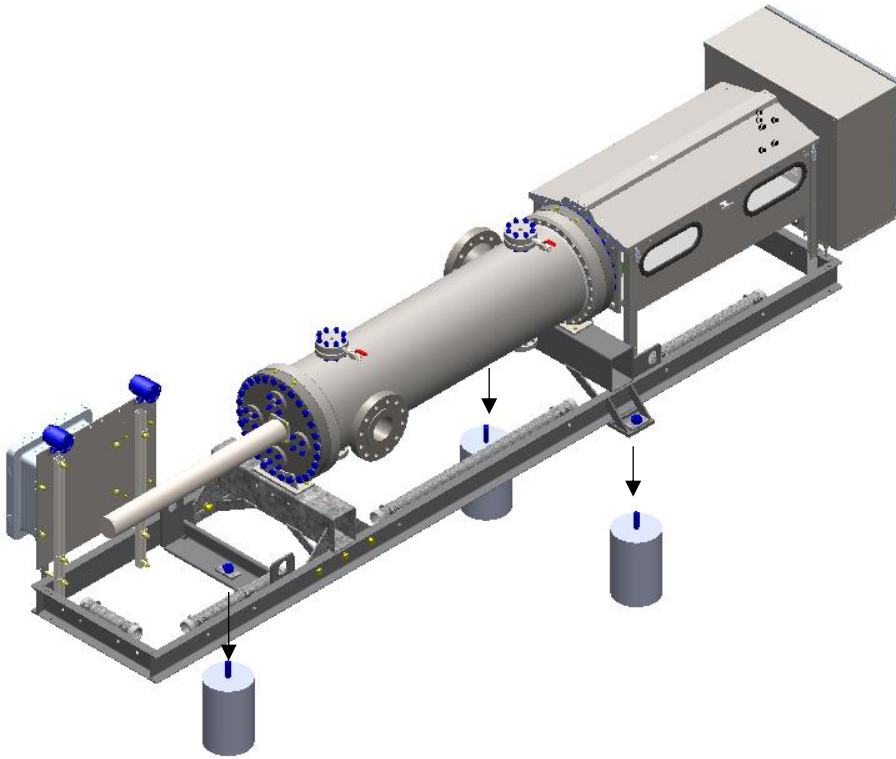

PYLON MOUNTED

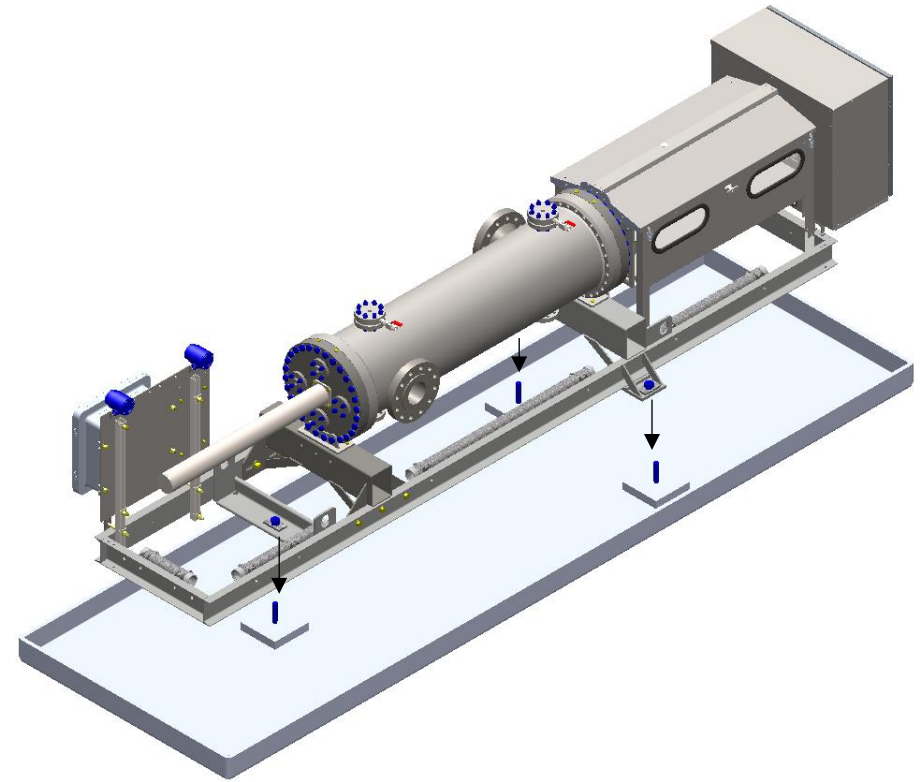

CONTAINMENT PAD

The 3 point mounting pads are designed to give the user easy access and eliminate any wobbling or stress to the unit. The mounting pads have 2" [51mm] holes to allow for some tolerance alignment and adjustment. Use minimum 1" [25mm] studs or consult with local authority having jurisdiction, whichever diameter is larger. **The mounting hardware must be tightened after the pipeline is connected to the FMD Prover in order to reduce the stress to the prover and frame. Refer to FMD document 000-109892-DOC for allowable nozzle loads.**

# PRECAUTIONS

**The prover is a finely calibrated measurement instrument. Care must be taken to avoid undue stress and shock when installing.**

**Do not, cut, weld, grind, drill or otherwise modify any portion of the prover.**

**Prover contains electronic and plated components that can be harmed by welding or by any industrial equipment that can cause a voltage spike or induce electrical current through the prover. Do not weld on any portion of the prover as irreversible damage may occur. When welding on piping connected to the prover, be sure to follow proper grounding procedures to isolate the prover from electrical current paths.**

# INSTALLATION PAD

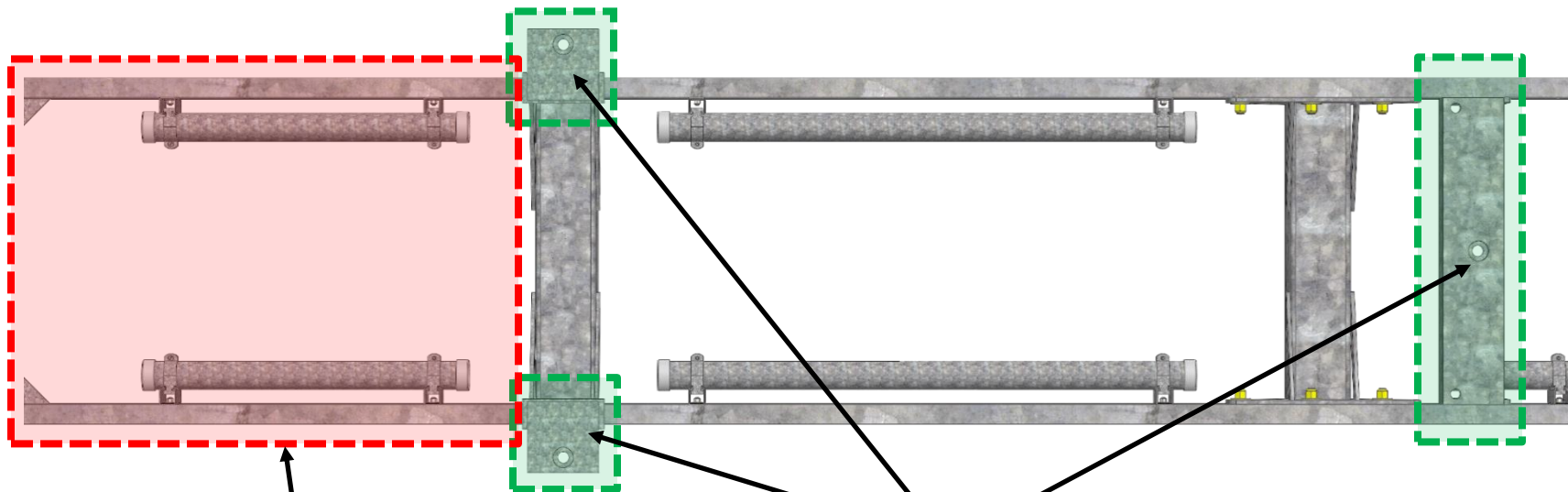

• Grouting NOT permitted

- Grouting permitted
- $\varnothing$  2" [51mm] Mounting holes

 **NOTE: DO NOT WELD  
ON FRAME OR  
PROVER**