

L1 - ENCLOSURE PIM

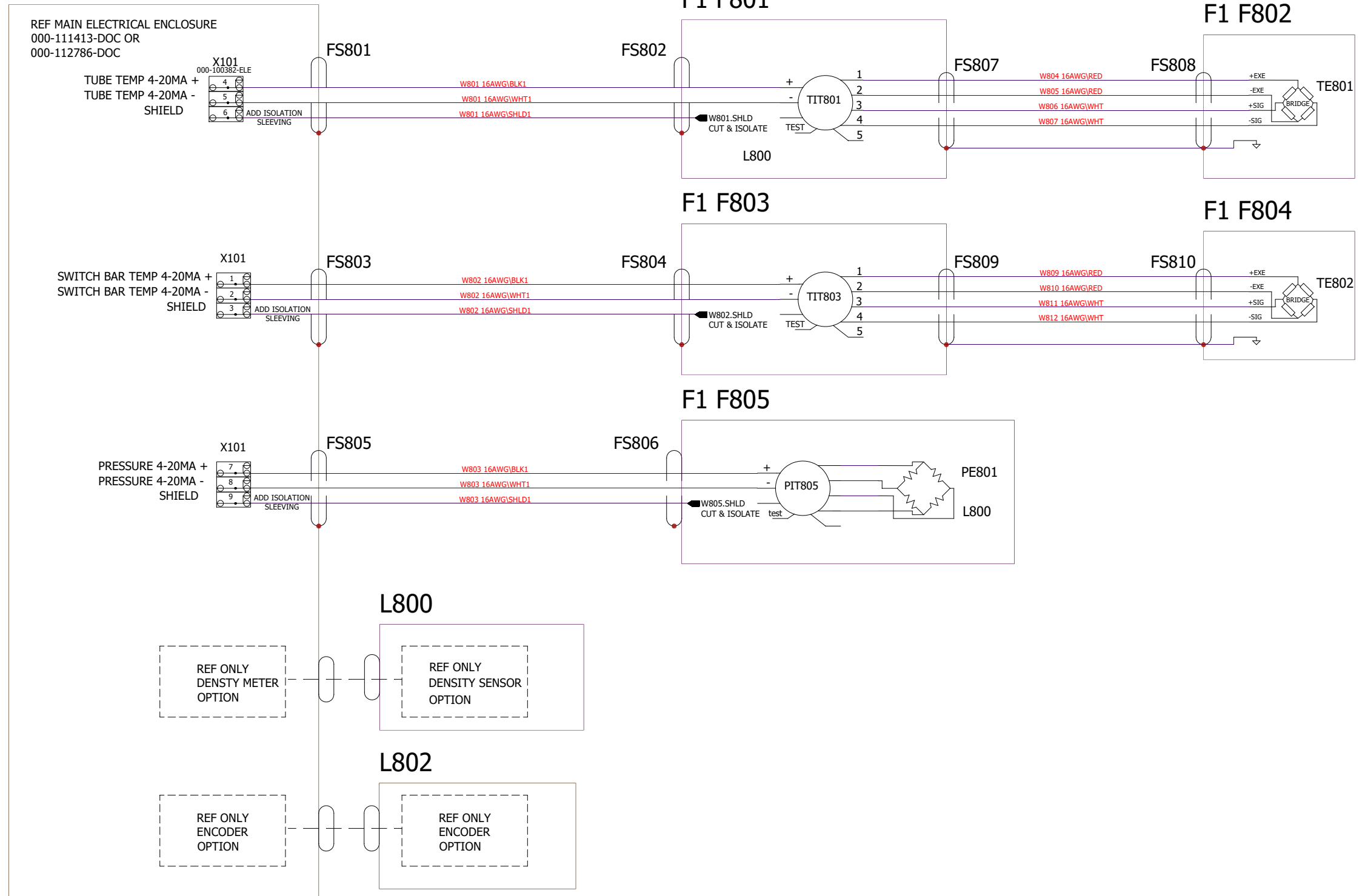

REFERENCE DESIGNATORS:
 FS-FITTING SET (ENCLOSURE ENTRY)
 K-RELAYS(ALL-OPTO)
 PS-POWER SUPPLIES
 P-CONNECTOR PLUG (SOC)
 J-CONNECTOR JACK (PIN)
 F-FUSE
 CB-CIRCUIT BREAKER
 M-MOTOR/CLUTCH
 L-ENCLOSURE
 R-RESISTOR
 D-DIODE
 S-SWITCH
 X-TERMINAL BLOCKS

NOTES:
 1) ALL SCREW TERMINAL CONNECTIONS SHALL HAVE CRIMP FERRULES.
 2) ALL PUSH IN TERMINAL CONNECTIONS SHALL BE TINED WITH SOLDER
 3) ALL TWIST-ON CONNECTIONS TO BE SOLDERED TOGETHER
 4) WIRE LABELS TO BE INSTALLED AT THE ENDS OF EACH WIRE WITH TARGET PIN, WIRE NUMBER AND BASIC FUNCTION. EXAMPLE: (J21.2 W20 LAUNCH). WIRE LABELS TO BE READABLE FROM LEFT TO RIGHT IN THE HORIZONTAL AXIS AND TOP TO BOTOM IN ALL OTHER AXIS.
 5) ALL WIRE(S) ENTERING ENCLOSURES SHALL BE PROTECTED WITH HEAT SHRINK WHERE CONTACT WITH SHARP EDGES EXIST.
 6) WIRE WRAPS SHALL BE STAINLESS.
 7) FSx FITTING SETS AND FCx CABLE DETERMINED BY BILL OF MATERIALS.
 8) HAZARDOUS AREA RATING DETERMINED BY PROVER MODEL NUMBER

NOTIFIED BODY APPROVED DOCUMENT
 CSA244391 CLASS 1, DIVISION 1
 ATEX Ex d mb [ia] IIB T3 Gb
 IECEx Ex d mb [ia] IIB T3 Gb
 NO CHANGES ALLOWED TO THIS DOCUMENT WITHOUT APPROVAL OF NOTIFIED BODY OR CERTIFICATION AGENCY



Flow Management Devices, LLC
 5225 S 37th St, Suite 4
 Phoenix, Az 85040
 602-233-9885

DOC-SYSTEM-WIRING-SENSORS-STD

NAME	DATE	TITLE
DRAWN Rob.Kalis	9/13/2017	SYSTEM-WIRING-SENSORS-STD
LAST REVISED TIM M.	04/16/2020	P/N: 000-111418-DOC
CHECKED		MODEL#:
SO#:		
SHEET 01 OF 01		REVISION E