

L500 - PROVER POWER

L501 - PROVER DRIVE

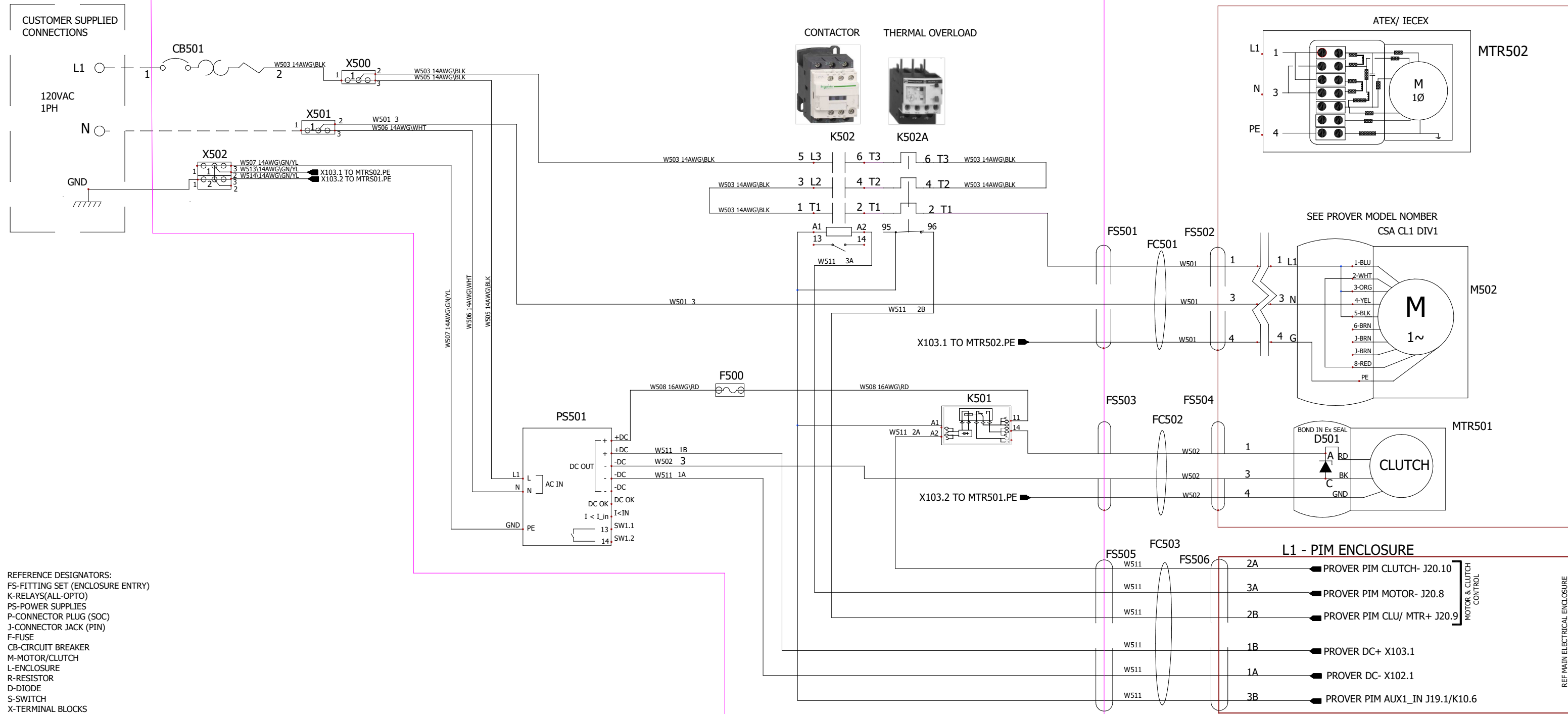

- REFERENCE DESIGNATORS:
 FS-FITTING SET (ENCLOSURE ENTRY)
 K-RELAYS(ALL-OPTO)
 PS-POWER SUPPLIES
 P-CONNECTOR PLUG (SOC)
 J-CONNECTOR JACK (PIN)
 F-FUSE
 CB-CIRCUIT BREAKER
 M-MOTOR/CLUTCH
 L-ENCLOSURE
 R-RESISTOR
 D-DIODE
 S-SWITCH
 X-TERMINAL BLOCKS

- NOTES:
 1.ALL SCREW TERMINAL CONNECTIONS SHALL HAVE CRIMP FERRULES.
 2.ALL PUSH IN TERMINAL CONNECTIONS SHALL BE TINED WITH SOLDER.
 3.ALL TWIST-ON CONNECTIONS TO BE SOLDERED TOGETHER.
 4.WIRE LABELS TO BE INSTALLED AT THE ENDS OF EACH WIRE WITH TARGET PIN, WIRE NUMBER, AND BASIC FUNCTION. EXAMPLE (J21.2 W20 LAUNCH). WIRE LABELS TO BE ORIENTED SO THEY ARE VISIBLE. WIRE LABELS TO BE READABLE FROM LEFT TO RIGHT IN THE HORIZONTAL AXIS AND TOP TO BOTTOM IN ALL OTHER AXIS.
 5.ALL WIRE(S) ENTERING ENCLOSURES SHALL BE PROTECTED WITH HEAT SHRINK WHERE CONTACT WITH SHARP EDGES EXIST.
 6.EXTERNAL WIRE WRAPS SHALL BE STAINLESS.
 7.FSX FITTING SETS AND FCX CABLE DETERMINED BY BILL OF MATERIALS.
 8.HAZARDOUS AREA RATING DETERMINED BY PROVER MODEL NUMBER.

NOTIFIED BODY APPROVED DOCUMENT
 CSA244391 CLASS 1, DIVISION 1
 ATEX Ex d mb [ia] IIB T3 Gb
 IECEx Ex d mb [ia] IIB T3 Gb
 NO CHANGES ALLOWED TO THIS DOCUMENT WITHOUT APPROVAL OF NOTIFIED BODY OR CERTIFICATION AGENCY

COND	COLOR	AWG	COLOR	mm ²
1	RED	14	BRN	2.5
2	BLU	14	GRY	2.5
3	BLK	14	BLK	2.5
4	BARE	14	GRN/YEL	2.5

COND	CSA C/US CL 1 DIV 1		ATEX/IEC	
	COLOR	AWG	COLOR	mm ²
1A	WHT 1	18	1	1.5
1B	BLK 1	18	2	1.5
2A	WHT 2	18	3	1.5
2B	BLK 2	18	4	1.5
3A	WHT 3	18	5	1.5
3B	BLK 3	18	6	1.5
SPARE	NA	NA	7	1.5

Flow Management Devices, LLC
 5225 S 37St Suite 4
 Phoenix, Az 85040
 602-233-9885

SYSTEM WIRING POWER 1 PHASE (110-120)V

NAME	DATE	TITLE:
LAST REVISED: sanket.gujarathi	4/13/2020	SYSTEM WIRING PWR 1PH 120V
DRAWN: kazi.hussain	2/7/2020	P/N: 000-111415-DOC
CHECKED:		MODEL#:
SO#:		
SHEET 01 OF 01		REVISION E