

FPSO and OffShore Measurement Technology Update

A downsized solution for applications where size matters

Written by: Steve Stewart



FPSO and Offshore Measurement Technology Update A Downsized Solution for Applications Where Size Does Matter

A Meter Prover Option to Reduce Weight, Reduce Footprint and Increase Accuracy



The inherent benefits of FMD's Small Volume Prover (SVP) technology is a natural solution for the footprint and weight challenges encountered by FPSO and Offshore measurement systems.

FPSO APPLICATIONS OVERVIEW

While FPSO and offshore measurement systems must maintain the same critical custody transfer measurement standards that apply to land-based facilities, these floating or fixed base marine platforms have additional challenges that do not apply to onshore metering stations.

System Weight & Footprint

For FPSO and Offshore design engineers, perhaps the most critical design considerations focus on the physical size, system buoyancy, and system weight. In fact, controlling or reducing component size and system weight can significantly impact the total system ROI and costs reflected in both CAPEX and OPEX.

FPSO Measurement Challenge: Performance VS Mass

In FPSO metering systems, the primary design challenge is to create a measurement system for discharging crude batches rapidly, accurately, and safely. Historically, these offshore metering station designs adopted the same designs as onshore systems, paying little attention to requirements for reduced weight or reduced footprint.

The Flow MD "Not So Small" Small Volume Prover, a Measurement Solution for FPSO's

There is a solution that drastically cuts weight, frees up space, and simplifies the design. FMD's SVP prover technology offers a low cost, more accurate solution providing up to a 90% reduction in mass and footprint while working with flow tube volume of only 4 barrels.

FMD SVP Technology VS Conventional Options

Typically, pipe provers built for FPSO flow rates are sized to work with flow tube volumes of 200 to 300 barrels, utilizing bulky 4-way valves, valve actuators, and large diameter launch chambers. In order to fit these oversized components onto the crowded deck or platform space, system designs were compacted to minimize the footprint. The trade-off for compact design is an overweight, jam-packed skid that creates difficulty when accessing components for field service or system maintenance. See illustration (1) FPSO example of pipe prover mounted underneath Quad-12" meter station.



Illustration (1)
Compact Meter Skid/Prover Design with 30" ball prover mounted underneath meter runs.

See Chart 2 (below), illustrating the complete line of Flow MD Provers.

Please note the size difference of the largest small volume prover in comparison to the 30" Ball Prover in illustration 1 shown above.

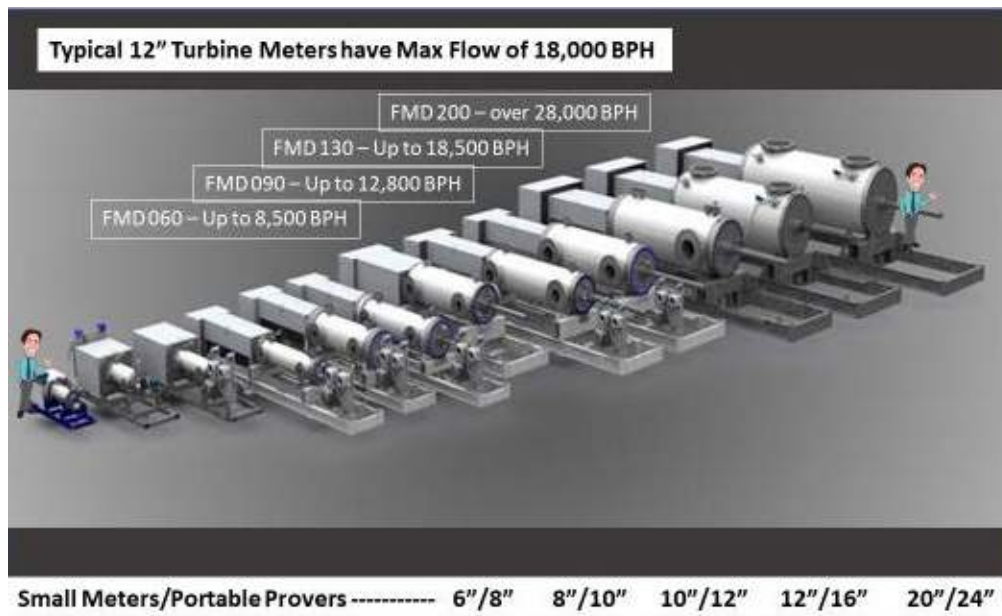



Besides reduced weight, reduced footprint, and improved accuracy...

FMD SVP Prover technology benefits include:

STANDARD DESIGN

All FMD provers have a standard design, standard model numbers, and standard factory replacement components.

TURNDOWN

FMD provers have a standard 1200-1 turndown VS 5-1 for conventional ball provers, allowing for the capability to expand performance ranges if flow rates change over time.

FASTER PROVING RUNS

Meter Proving is faster; allowing faster calibration to quickly establish meter factors for batches or ship loading.

GRAVIMETRIC WATER DRAW CALIBRATIONS

There are two primary types of waterdraw (prover calibration) methods for certifying SVP provers, volumetric and gravimetric. Generally, the most accurate and repeatable method for certifying SVP technology is the gravimetric method. SVP water draw services can be performed at certified laboratories or certification can take place in the field or offshore locations using a certified mobile gravimetric water draw laboratory mounted on a trailer or skid.

FMD PROVER TECHNOLOGY VS CONVENTIONAL PROVERS

Eliminates the typical issues seen with prover ball and accessories, the 4-way valve and actuator, as well as pipe coating issues.

FMD PROVER TECHNOLOGY VS MASTER METER PROVING

Generally, it is agreed that direct "in-situ" proving methods are more accurate and more repeatable than master meter proving. Considering the weight and size comparisons of a master meter system and FMD provers are similar, the benefit of direct proving is a better option for long-term performance and system accuracy.

SERVICE IS EASIER & LESS EXPENSIVE

Due to the smaller volumes in SVPs and the smaller component design, water draw process and field repairs can typically be performed in one or two days minimizing service expense and downtime. See Figure (3) Next Page

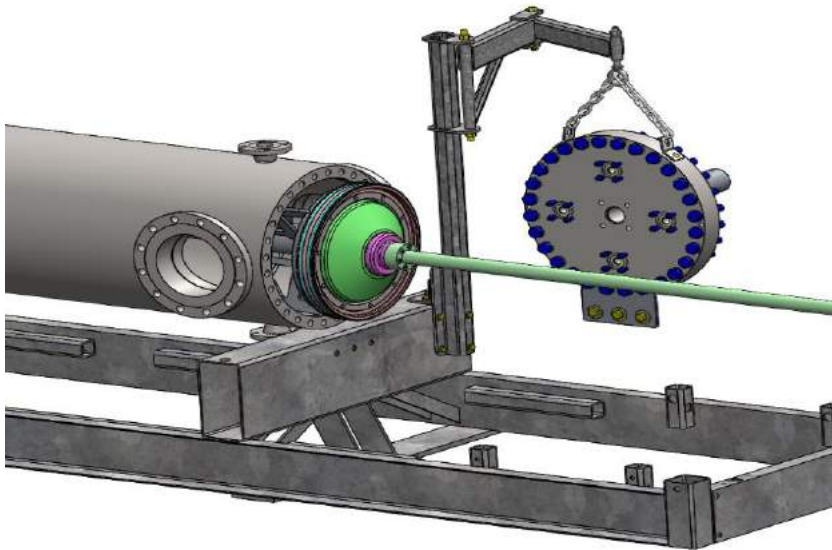

Figure 3
Self-contained davit option
eliminates the need for a crane.
Minimizing both time and expense
of service.

SVP – Meter Technology Compatibility

There are four main meter technologies in use today for custody transfer crude measurement applications that utilize API standards. They are Positive Displacement Meters, Turbine Meters, Coriolis Meters, and Ultrasonic Meters. The standard meter sizes used for custody transfer typically range from under 2 inches up to 16 inches. In some cases, 20 inch, 24 inch, 30 inch, and larger meters may be used, but due to uncertainty issues, logistics, weight, turn-down, and calibration issues, the majority of liquid petroleum API custody transfer is conducted in meters 16 inch or smaller.

FMD's recent update and redesign of their SVP, led to the introduction of the new 4th Gen SVP technology. All meter technologies listed here can, and have been paired successfully with FMD SVP provers. Additionally, SVP technology can be provided in large size provers designed to prove flow meters sized for up to 35,000 Barrels per hour. Please note that all meter technology and meter prover pairing selections have unique application considerations. All flow meter and meter prover projects should be reviewed and approved by the proper application engineers.

SVP Selection Criteria - If You Can Meter It, An SVP Can Prove It

There are many application considerations when selecting the proper SVP proving device; fluid pressure, fluid temperature, fluid physical characteristics, accuracy requirements, flow rates, flow meter technology, measurement turn-down requirements, environment, operational costs, local agency acceptance as well as others. All of these parameters should be subject to thorough review as part of the meter and prover selection decision.

For additional information, contact Flow Management Devices

sales@flowmd.com - www.flowmd.com - 602-233-9985