

FMDC25

Data Sheet

Unidirectional Captive Displacement Prover



The Flow MD Unidirectional Captive Displacement Provers set the standard in small volume proving. With an innovative and patented drive-end, the Flow MD line of provers provides superior design and functionality.



FMDC25 Specifications

Max Flow Rate	GPM	BPH	M ³ H	
	2,500	3,570	560	
Displaced Volume	Gallons		Liters	
	Primary	Secondary	Primary	Secondary
	20	15	75	60
Std Flange Size	6" ANSI			
Turndown	1200 : 1			

Approvals & Certifications

ISO	9001:2008 Cert# 0110-156-2, 17025:2005 Cert # L14240
EC	Mach Dir:2006/42/EC, EN 12100-2:2003, ATEX Directive 94/9/EC, EN 13463-1:2009, EN 13463-5:2003, EN 60079-0, EN 60079-7, EN 60079-11
CSA (US & Canada)	Class 3218 06, Class 1 Div 1 Group D; Class 1 Div 2 Group D / Clutch & Brake Assembly - EX m IIC T5
IECEX	USA /ETL/QAR 15.0014/00 , 101653329CRT-002
ABSA	CRN: OF1072.2

Key Features:

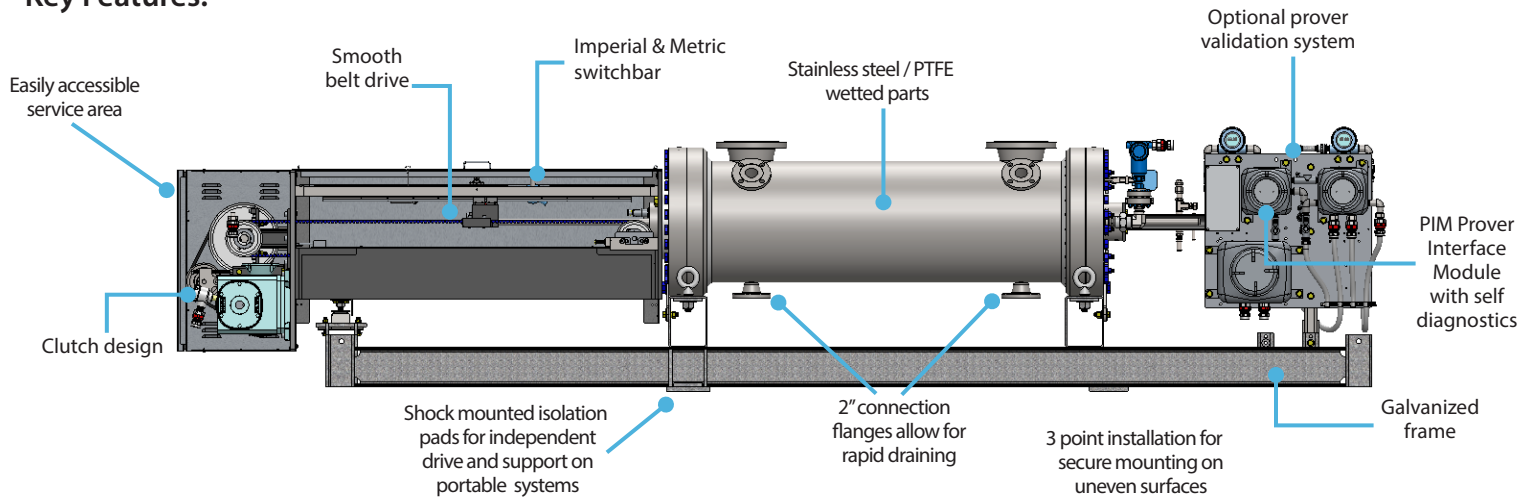

Included in Standard Prover Package

P.I.M Electronics Module



Vent Manifolds (2)

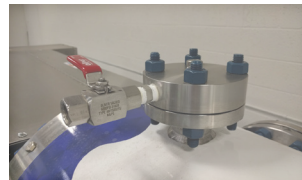

Electrical Connections



Check out the Prover Accessories Brochure for additional options

"In pursuit of improving liquid and gas measurement technology"

Flow Management Devices, LLC

+1.602.233.9885
 F: 602.233.9887
 E: sales@flowmd.com
 www.flowmd.com
 5225 S. 37th St # 4
 Phoenix, AZ 85040 USA

FMDC25

Dimensional Drawings

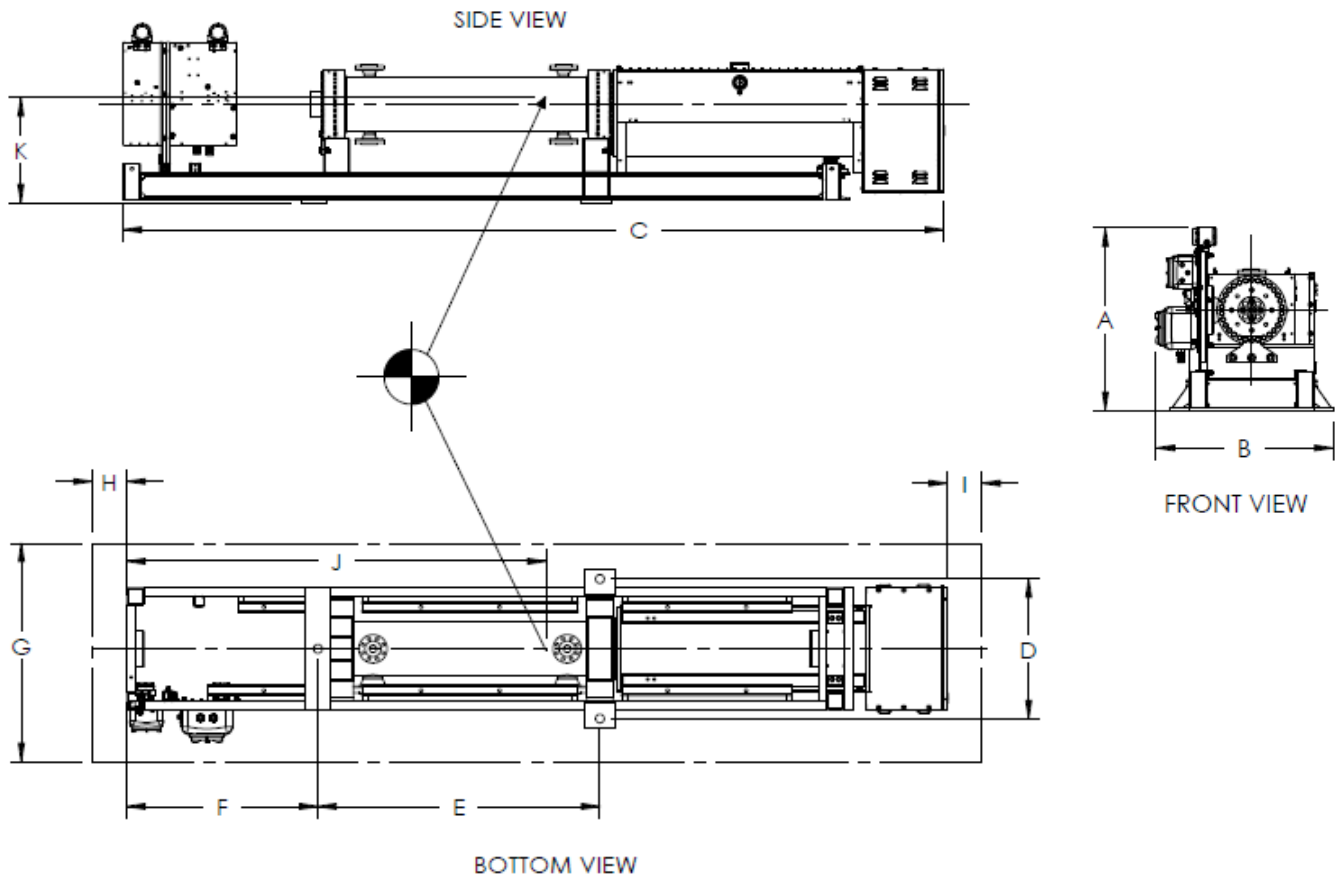

Weights	Weight (+/- 5%)		Weight w/ Crate (+/- 5%) LBS	Weight Filled w/ Water (+/- 5%) LBS
	LBS	KGS		
ANSI Pressure 150 #	3,980	1,805	4,380	4,360
ANSI Pressure 300 #	4,030	1,828	4,430	4,410
ANSI Pressure 600 #	4,275	1,939	4,675	4,655
ANSI Pressure 900 #	4,325	1,962	4,725	4,705

Dimensions		A	B	C	D	E	F	G	H	I	J	K
Model	Pressure Rating											
FMDC25	150/300 #	41	40	166	32	67	33	100	30	30	57	22
FMDC25	600/900 #	41	40	168	32	68	33	100	30	30	53	25

Drawing Notes:

- DIMENSIONS "J" AND "K" ARE FOR CENTER OF GRAVITY WITHIN 6 INCHES
- DIMENSIONS "A", "B" AND "C" ARE OVERALL DIMENSIONS
- SPACIAL DIMENSIONS HAVE A TOLERANCE OF +/- 1.00 INCHES
- DIMENSIONS "G", "H" AND "I" ARE FOR SERVICE ZONE
- ALL DIMENSIONS ARE SUBJECT TO CHANGE WITHOUT NOTICE

Energy Consumption	Motor Voltage/Phase Availability & Amperage Draw												
	Motor Size	24 VDC	120 VAC	220 VAC	220 VAC 3 PHZ	240 VAC 3 PHZ	208/230 VAC 3 PHZ	380 VAC 3 PHZ	400 VAC 3 PHZ	415 VAC 3 PHZ	440 VAC 3 PHZ	460 VAC 3 PHZ	480 VAC 3 PHZ
	1 hp	40	13**	6.5**	3.2**	3.2**	3.2**	2**	2*	2*	1.6**	1.6**	1.6**

* 50 Hz Operation Only

** 50 OR 60 Hz Operation

*** 60 Hz Operation Only

