

FMDA35

Data Sheet

Unidirectional Captive Displacement Prover



The Flow MD Unidirectional Captive Displacement Provers set the standard in small volume proving. With an innovative and patented drive-end, the Flow MD line of provers provides superior design and functionality.

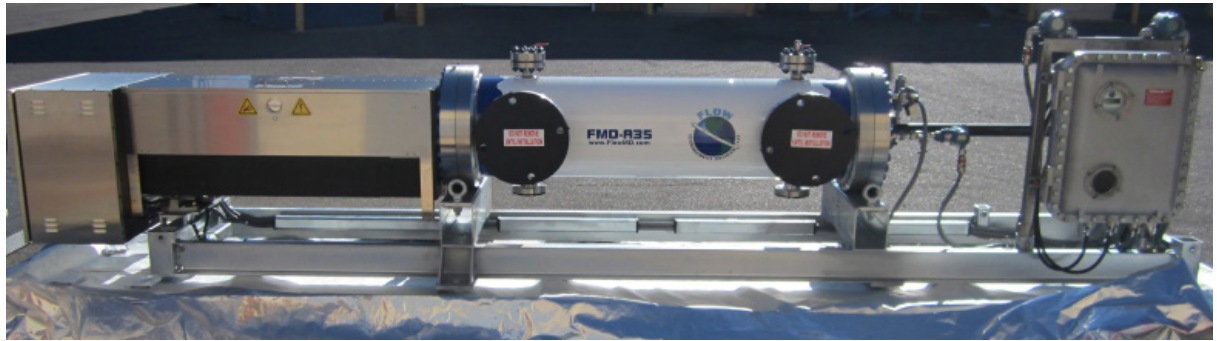

FMDA35 Specifications



Max Flow Rate	GPM	BPH	M ³ H	
	3,500	5,000	790	
Displaced Volume	Gallons		Liters	
	Primary	Secondary	Primary	Secondary
	25	20	95	75
Std Flange Size	8" ANSI			
Turndown	1200 : 1			

Approvals & Certifications

ISO	9001:2008 Cert# 0110-156-2, 17025:2005 Cert # L14240
EC	Mach Dir:2006/42/EC, EN 12100-2:2003, ATEX Directive 94/9/EC, EN 13463-1:2009, EN 13463-5:2003, EN 60079-0, EN 60079-7, EN 60079-11
CSA (US & Canada)	Class 3218 06, Class 1 Div 1 Group D; Class 1 Div 2 Group D / Clutch & Brake Assembly - EX m IIC T5
IECEX	USA /ETL/QAR 15.0014/00, 101653329CRT-002
ABSA	CRN: OF1072.2

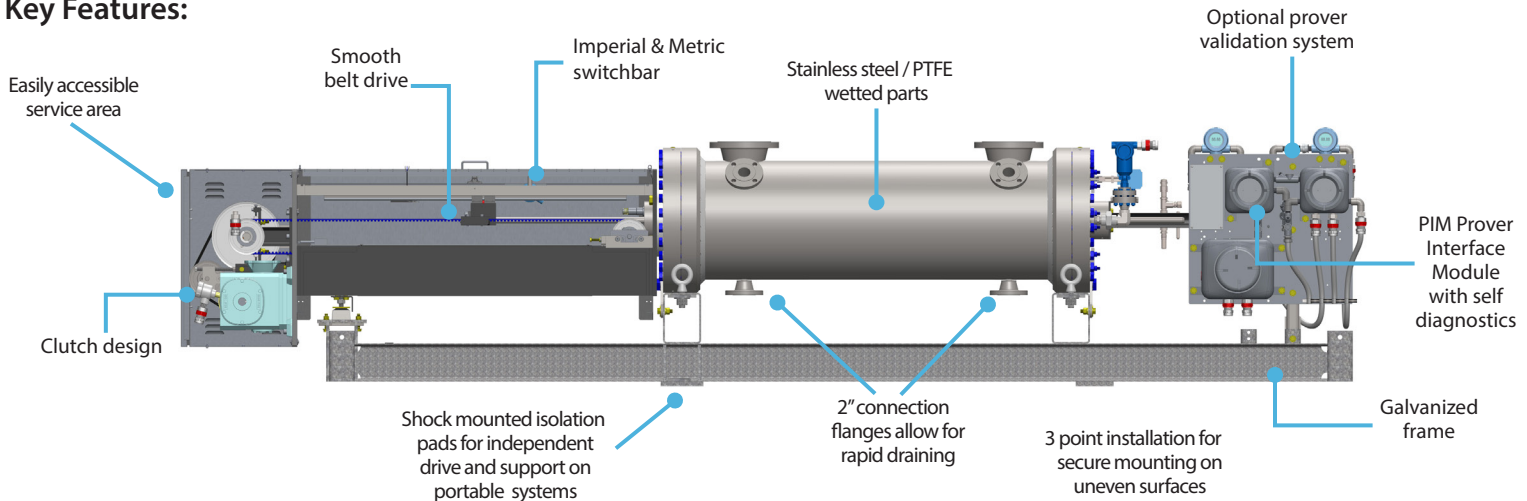
Key Features:

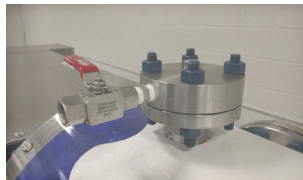

Included in Standard Prover Package	P.I.M Electronics Module 	Vent Manifolds (2) 	Electrical Connections 
--	--	---	--

Check out the Prover Accessories Brochure for additional options

"In pursuit of improving liquid and gas measurement technology"

Flow Management Devices, LLC

+1.602.233.9885
 F: 602.233.9887
 E: sales@flowmd.com
 www.flowmd.com
 5225 S. 37th St # 4
 Phoenix, AZ 85040 USA

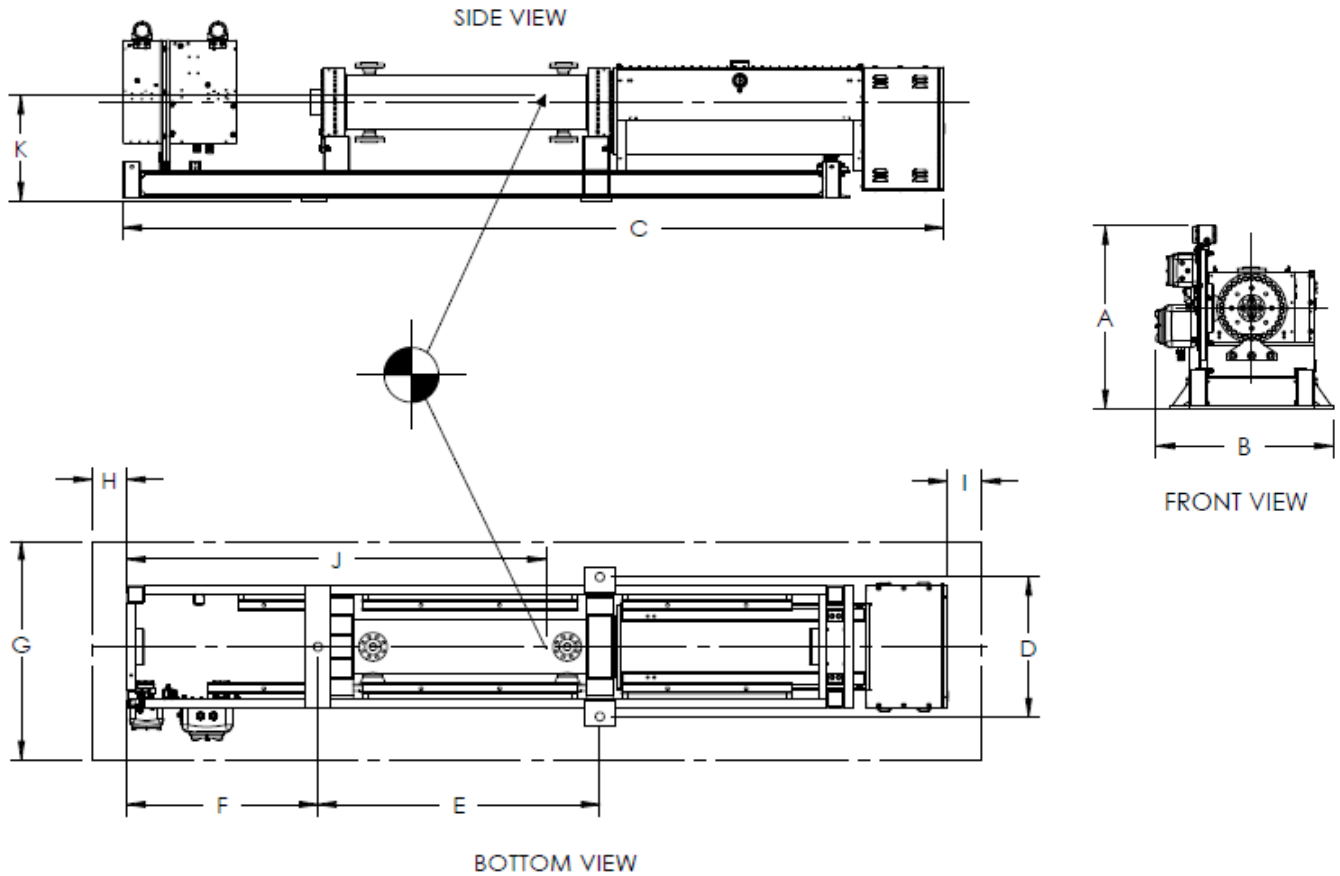

Weights	Weight (+/- 5%)		Weight w/ Crate (+/- 5%) LBS	Weight Filled w/ Water (+/- 5%) LBS
	LBS	KGS		
ANSI Pressure 150 #	4,850	2,199	5,590	5,450
ANSI Pressure 300 #	4,920	2,231	5,660	5,520
ANSI Pressure 600 #	5,370	2,435	6,110	5,970
ANSI Pressure 900 #	5,430	2,463	6,170	6,030

Dimensions (inches)		A	B	C	D	E	F	G	H	I	J	K
Model	Pressure Rating											
FMDA35	150/300 #	41	40	214	32	80	54	100	30	30	108	29
FMDA35	600/900 #	41	40	214	32	80	54	100	30	30	108	29

Drawing Notes:

1. DIMENSIONS "J" AND "K" ARE FOR CENTER OF GRAVITY WITHIN 6 INCHES
2. DIMENSIONS "A", "B" AND "C" ARE OVERALL DIMENSIONS
3. SPACIAL DIMENSIONS HAVE A TOLERANCE OF +/- 1.00 INCHES
4. DIMENSIONS "G", "H" AND "I" ARE FOR SERVICE ZONE
5. ALL DIMENSIONS ARE SUBJECT TO CHANGE WITHOUT NOTICE

Energy Consumption	Motor Voltage/Phase Availability & Amperage Draw												
	Motor Size	24 VDC	120 VAC	220 VAC	220 VAC 3 PHZ	240 VAC 3 PHZ	208/230 VAC 3 PHZ	380 VAC 3 PHZ	400 VAC 3 PHZ	415 VAC 3 PHZ	440 VAC 3 PHZ	460 VAC 3 PHZ	480 VAC 3 PHZ
	1 hp	40	13**	6.5**	3.2**	3.2**	3.2**	2**	2*	2*	1.6**	1.6**	1.6**

* 50 Hz Operation Only

** 50 OR 60 Hz Operation

*** 60 Hz Operation Only

