

FMD200

Data Sheet

Unidirectional Captive Displacement Prover



The Flow MD Unidirectional Captive Displacement Provers set the standard in small volume proving. With an innovative and patented drive-end, the Flow MD line of provers provides superior design and functionality.



FMD200 Specifications



Max Flow Rate	GPM	BPH	M ³ H	
	20,000	28,500	4,500	
Displaced Volume	Gallons		Liters	
	Primary	Secondary	Primary	Secondary
	140	100	500	400
Std Flange Size	20" ANSI B16.5			
Turndown	1200 : 1			

Approvals & Certifications

ISO	9001:2008 Cert# 0110-156-2, 17025:2005 Cert # L14240
EC	Mach Dir:2006/42/EC, EN 12100-2:2003, ATEX Directive 94/9/EC, EN 13463-1:2009, EN 13463-5:2003, EN 60079-0, EN 60079-7, EN 60079-11
CSA (US & Canada)	Class 3218 06, Class 1 Div 1 Group D; Class 1 Div 2 Group D / Clutch & Brake Assembly - EX m IIC T5
IECEX	USA /ETL/QAR 15.0014/00, 101653329CRT-002
ABSA	CRN: OF1072.2

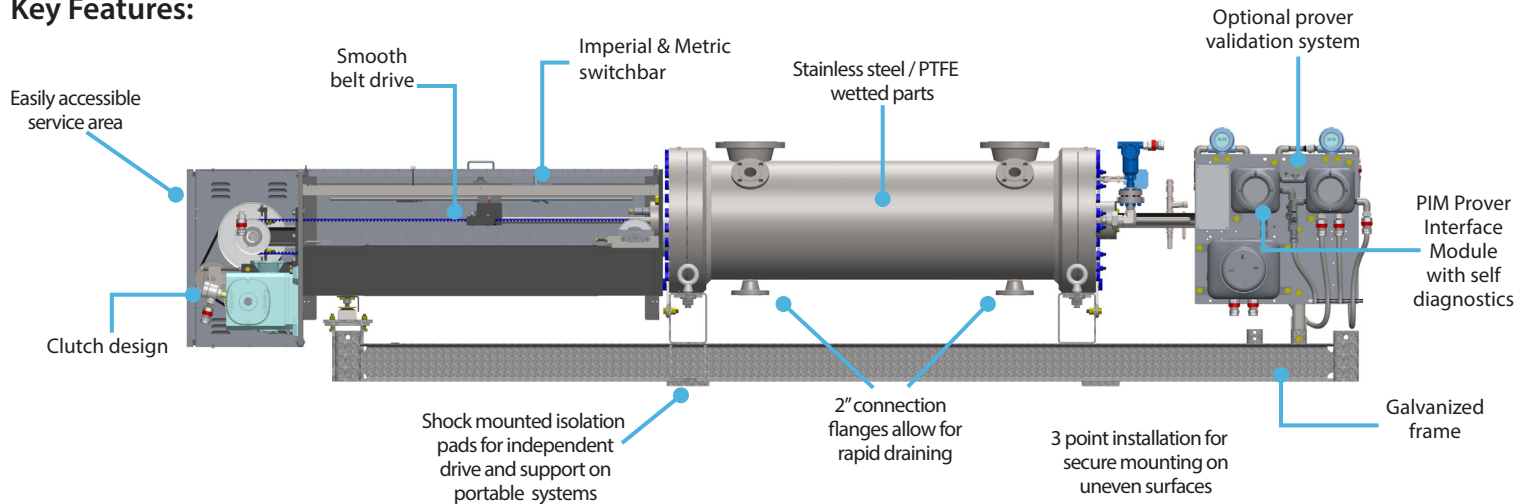
Key Features:

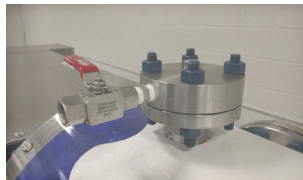

<p>Included in Standard Prover Package</p>	<p>P.I.M Electronics Module</p> 	<p>Vent Manifolds (2)</p> 	<p>Electrical Connections</p> 
---	---	--	---

Check out the Prover Accessories Brochure for additional options

“In pursuit of improving liquid and gas measurement technology”

Flow Management Devices, LLC

+1.602.233.9885
 F: 602.233.9887
 E: sales@flowmd.com
 www.flowmd.com
 5225 S. 37th St # 4
 Phoenix, AZ 85040 USA

FMD200

Dimensional Drawings

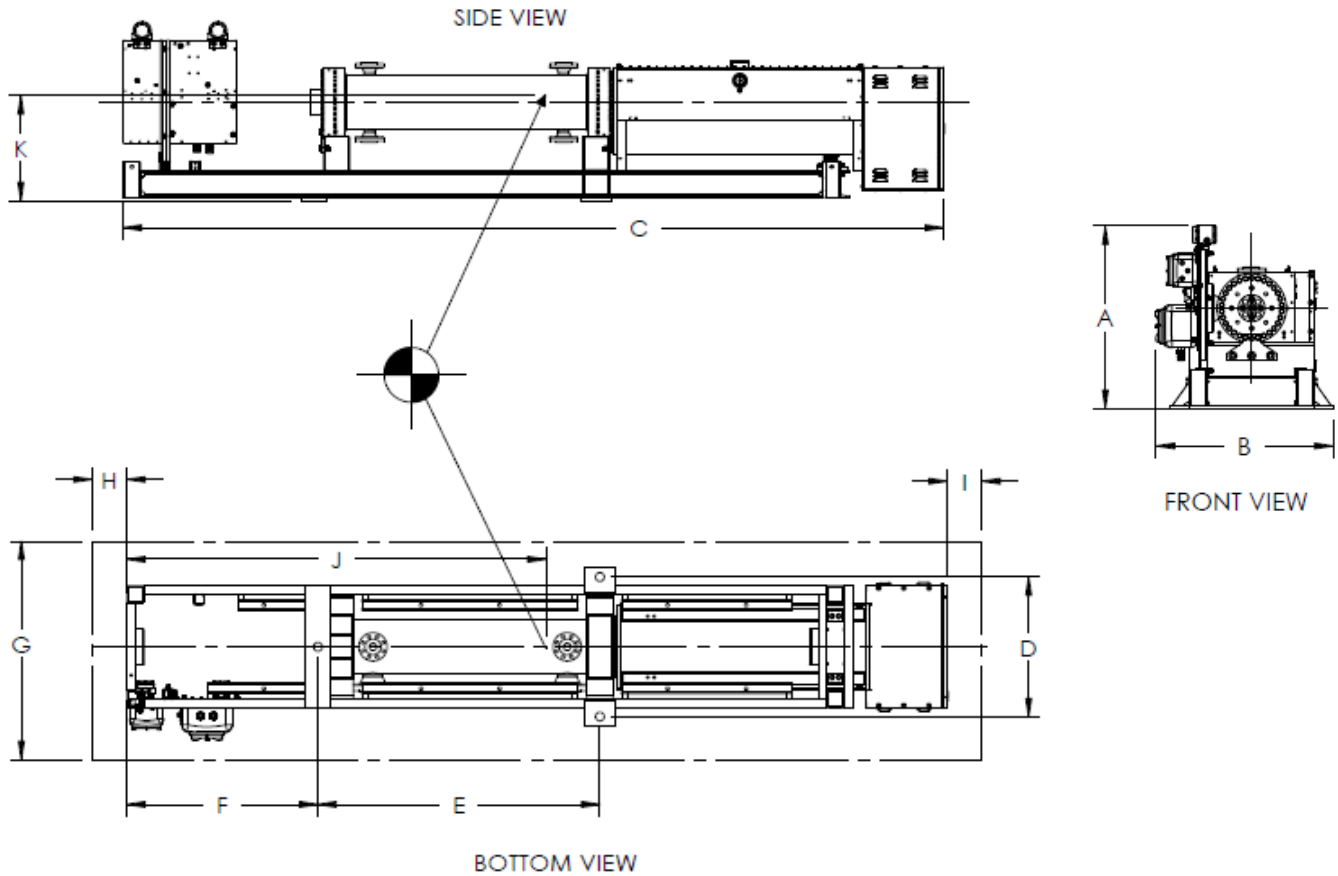

Weights	Weight (+/- 5%)		Weight w/ Crate (+/- 5%) LBS	Weight Filled w/ Water (+/- 5%) LBS
	LBS	KGS		
ANSI Pressure 150 #	18,410	8,350	22,770	22,890
ANSI Pressure 300 #	24,280	11,015	28,640	28,760

Dimensions (inches)		A	B	C	D	E	F	G	H	I	J	K
Model	Pressure Rating											
FMD200	150/300 #	69	74	253	63	104	61	131	30	30	152	39
FMD200	600/900 #	69	74	253	63	104	61	131	30	30	152	39

Drawing Notes:

1. DIMENSIONS "J" AND "K" ARE FOR CENTER OF GRAVITY WITHIN 6 INCHES
2. DIMENSIONS "A", "B" AND "C" ARE OVERALL DIMENSIONS
3. SPACIAL DIMENSIONS HAVE A TOLERANCE OF +/- 1.00 INCHES
4. DIMENSIONS "G", "H" AND "I" ARE FOR SERVICE ZONE
5. ALL DIMENSIONS ARE SUBJECT TO CHANGE WITHOUT NOTICE

Energy Consumption	Motor Voltage/Phase Availability & Amperage Draw								
	Motor Size	220 VAC 3 PHZ	240 VAC 3 PHZ	208/230 VAC 3 PHZ	380 VAC 3 PHZ	400VAC 3 PHZ	440 VAC 3 PHZ	460 VAC 3 PHZ	480 VAC 3 PHZ
	7.5 hp	20.2**	20.2**	20.2**	12.3**	12.3**	10.1**	10.1**	10.1**

** 50 OR 60 Hz Operation

