









LEGEND		CUSTOMER TAG#
	PROCESS LINE	
	1/2" SST TUBING	
	ANALOG ELEC. SIGNAL	
	DENSITY METER SENSOR	
	DENSITY METER TRANSMITTER	
	CHECK THERMOWELL	
	TRANSMITTER JUNCTION BOX	
	PRESSURE GAUGE	



PROPRIETARY AND CONFIDENTIAL
 This document contains data that is proprietary to FlowMD, and may never, in whole or in part, be duplicated, disclosed to unauthorized persons, or used for manufacturing without prior written permission and authorization from FlowMD.

UNLESS OTHERWISE SPECIFIED:
 ALL DIMENSIONS ARE IN INCHES
 GENERAL DRAWING TOLERANCES:
 .X ± .030
 .XX ± .010
 .XXX ± .005
 ANGLES: ± 5°
 FRACTIONAL: ± 1/16"
 SURFACE FINISH 63 μINCH MAX ON MACHINED SURFACES
 REMOVE ALL SHARP EDGES & BURRS
 BREAK CORNERS .005/.020
 INTERPRET GEOMETRIC TOLERANCING PER: ASME Y.14.5M-2009

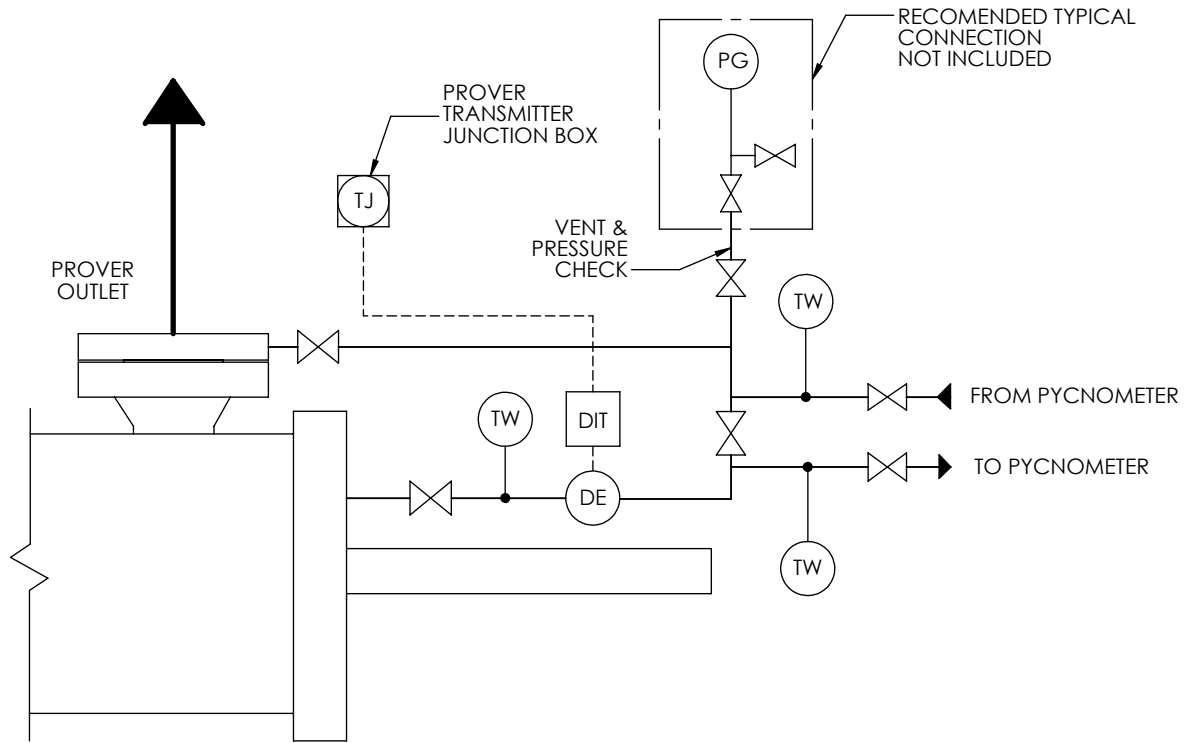
ALL DIMENSIONS, TOLERANCES, AND SPECIFICATIONS APPLY TO FINISHED ITEMS AFTER ANY APPLICABLE FINISH, PLATING, HEAT TREATING, ETC.

DO NOT SCALE DRAWING

	NAME	DATE
DRAWN	SETH M.	10/23/13
LAST REVISED		
CHECKED		
MATERIAL		
FINISH		

CONTACT INFORMATION
FLOW MANAGEMENT DEVICES
 5225 SOUTH 37TH ST SUITE 4
 PHOENIX, ARIZONA 85040
 PHONE: (602) 233-9885
 FAX: (602) 233-9887
www.FlowMD.com

FLOW MANAGEMENT DEVICES		
TITLE:	DOC ENG REF PYC LOOP P&ID	
P/N:	000-106951-DOC	
MODEL #:	ALL MODELS	
SIZE		REV A
SCALE: 1:8	WEIGHT:	SHEET 1 OF 1

FOR REFERENCE